

EN

Instructions for Fitting, Operating and Maintenance

Retractable Door

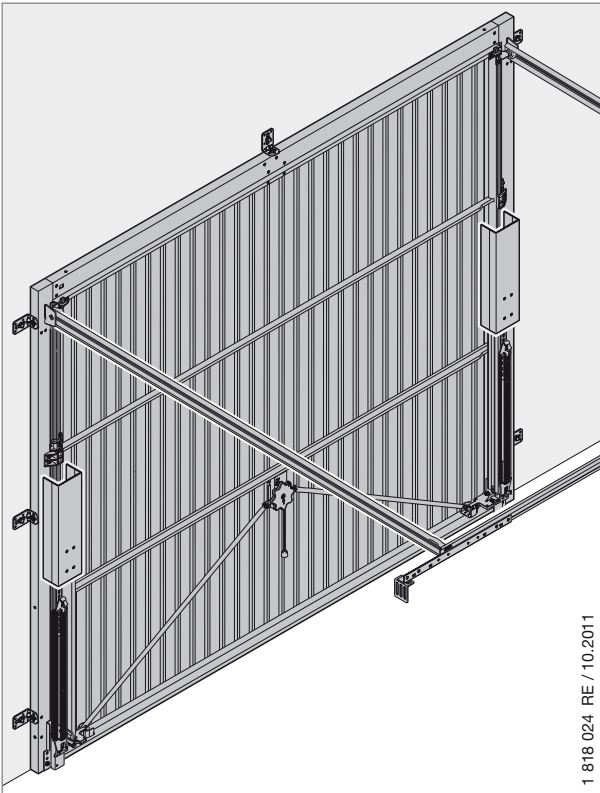

1 818 024 RE / 10.2011

Contents

1	⚠ Safety Instructions	3		
1.1	Qualified persons.....	3		
1.2	Symbols and signal words used.....	3		
1.3	Intended use.....	4		
1.4	General safety instructions.....	4		
2	Fitting and Initial Start-Up.....	5		
2.1	Safety instructions.....	5		
2.2	Fitting.....	5		
2.2.1	Doors with centre profile/ horizontal ribbing.....	7		
2.2.2	Fitting the handle.....	7		
2.2.3	Fitting to the ceiling.....	7		
2.2.4	Checking the door action and door stop.....	7		
2.3	Initial start-up.....	7		
2.3.1	Checking the door spring tension (Figure 8.3).....	7		
3	Operation.....	8		
3.1	Safety instructions.....	8		
3.2	Opening the door with the handle.....	8		
3.3	Locking and unlocking the door.....	8		
4	Inspection and Maintenance	9		
4.1	Safety instructions.....	9		
4.2	Checking the condition of the door.....	9		
4.3	Checking the door spring tension.....	9		
4.4	Replacing the door tension springs.....	9		
4.5	Checking the track rollers and tracks.....	10		
			4.6	Checking the lock and locking mechanism.....
			4.6.1	Adjusting the latching (Figure 9.1).....
			4.7	Accessories.....
			5	Surface Protection.....
			5.1	Door with steel infill.....
			5.2	Door with timber or GRP infill.....
			6	Cleaning and Care
			6.1	Door surfaces made of steel.....
			6.2	Synthetic panes.....
			6.3	Data plate.....
			7	Assistance with Malfunctions.....
			8	Dismantling
				
				12



Dissemination as well as duplication of this document and the use and communication of its content are prohibited unless explicitly permitted. Noncompliance will result in damage compensation obligations. All rights reserved in the event of patent, utility model or design model registration. Subject to changes.

Make sure that these instructions remain with the door operator!

Read and follow these instructions carefully!

They provide you with important information on safe fitting and operation, as well as proper care and maintenance of your garage door.

Keep these instructions and the warranty booklet with the declaration of conformity in a safe place.

Enter the serial number (see the data plate) here.
Serial no.:

1 Safety Instructions

The manufacturer is not liable for damage resulting from non-compliance with these instructions and the safety instructions.

1.1 Qualified persons

Have a qualified person (competent persons in acc. with EN 12635) fit, start-up and maintain the door following these instructions. While doing so, the requirements listed in the standards EN 12604 and EN 12635 must be observed.

1.2 Symbols and signal words used

Special safety information is provided at respective important points in these instructions. They are identified by the following symbols and signal words.



The general warning symbol indicates a danger that can lead to **injury or death**.



WARNING

Indicates a danger that can lead to death or serious injuries.



CAUTION

Indicates a danger that can lead to minor or moderate injuries.

ATTENTION

Indicates a danger that can lead to **damage or destruction of the product**.



Important note for avoiding damage to property



Permissible arrangement or activity



Non-permissible arrangement or activity

ENGLISH

See the text section (e.g. Section 2.2.1)



Inspect



Move component slowly



Dispose of components/packaging

1.3 Intended use

- The garage door is only intended for private use. If you would like to use the door in a commercial application, first check whether the currently valid national and international regulations permit such use.
- The garage door is suitable for use outside; it opens outwards with an up-and-over action.
- Doors without a threshold profile have a water tightness class 0.
- The garage door can be manually operated or fitted with an operator.

1.4 General safety instructions

- Always keep the swivelling and opening area of the door clear. When in operation, make sure that neither persons, children in particular, nor objects are located within the door's area of travel.
- Do not attach any additional components of another make! The tension springs are matched to the door leaf weight. Additional components can overload the springs.
- Do not alter or remove any components! You could otherwise risk putting important safety components out of action. Only use original parts intended for use with this particular garage door.
- Protect the door from caustic, aggressive substances, e.g. nitrous reactions from stones or mortar, acids, alkali solutions, de-icing salt, aggressive paints or sealants.
- Make sure that there is sufficient water run-off and ventilation (drying) in the lower section of the side frames and the threshold profile.
- Operation of the door during heavy winds may be dangerous.

2 Fitting and Initial Start-Up

2.1 Safety instructions

WARNING

Danger of injury

There is a danger of injury during fitting. Observe the following instructions:



- ▶ Wear safety glasses and protective gloves.



There is a danger of injury during fitting. Observe the following instructions:

- ▶ Check that the fixing materials supplied are suitable for the given structural condition. Only use suitable fixing material. Only fasten the door system to supporting structures with permission from the structural engineer.
- ▶ Secure the door from falling.
- ▶ Support the tracks properly.
- ▶ Secure the door leaf from crashing to the floor.
- ▶ Fit all delivered fastenings according to the fitting instructions.

ATTENTION

Damage to the product

Observe the following instructions:

- ▶ Protect the door frame along with the ball-bearing bracket and door leaf against drilling dust during fitting.
- ▶ Install a door with timber infill only in dry garages.

2.2 Fitting

Fitting to steel frame

The garage door can be fitted from the inside behind the opening or in the opening

Fitting to timber frame

ATTENTION

Damage of injury

- ▶ Check carefully the opening size and squareness of the timber frame (the door is manufactured slightly smaller to give the correct clearance between door leaf and timber frame.
- ▶ The timber frame should be of the „Goalpost“ type, with a minimum nominal size of 70 mm x 70 mm (2 2/3“ x 2 2/3“) once erected it should provide an inside frame dimension as detailed.

Door size	Inside frame dimension in Imperial	Inside frame dimension in Metric
6'6" x 6'6"	6'6" x 6'6"	1981 x 1981
6'6" x 7'0"	6'6" x 7'0"	1981 x 2134
6'10" x 6'4"	6'10" x 6'4"	2083 x 1931
7'0" x 6'4"	7'0" x 6'4"	2134 x 1931
7'0" x 6'6"	7'0" x 6'6"	2134 x 1981
7'0" x 7'0"	7'0" x 7'0"	2134 x 2134
7'3" x 6'4"	7'3" x 6'4"	2210 x 1931
7'5" x 6'6"	7'5" x 6'6"	2261 x 1981
7'5" x 7'0"	7'5" x 7'0"	2261 x 2134
7'6" x 6'4"	7'6" x 6'4"	2286 x 1931
7'6" x 6'6"	7'6" x 6'6"	2286 x 1981
7'6" x 7'0"	7'6" x 7'0"	2286 x 2134
7'8" x 6'4"	7'8" x 6'4"	2337 x 1931
8'0" x 6'4"	8'0" x 6'4"	2438 x 1931
8'0" x 6'6"	8'0" x 6'6"	2438 x 1981
8'0" x 7'0"	8'0" x 7'0"	2438 x 2134
9'0" x 6'6"	9'0" x 6'6"	2743 x 1981
9'0" x 7'0"	9'0" x 7'0"	2743 x 2134

All the dimensions stated in the illustrated section are in mm.

Door for on-site infill

⚠ CAUTION

Transport locking device / max. infill weight
 Observe the following instructions to avoid any injuries:

- ▶ First install the infill and then remove the transport locking device so that the door does not bounce up.
- ▶ Observe the maximum infill weight of 7 kg/m² for doors with an integrated wicket door so that the springs are not overloaded.

Maximum permissible infill weight for on-site infill:

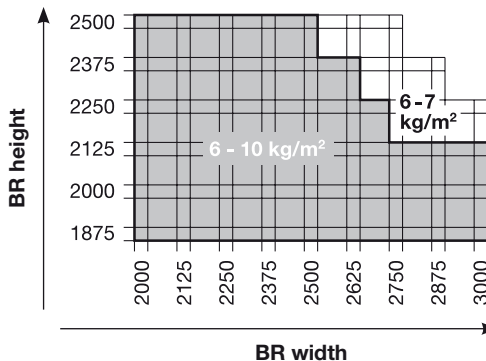

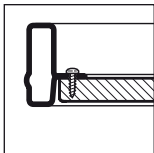

Infill in the frame

For on-site infill see also *supplement to instructions*.

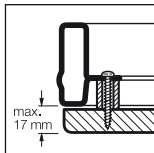

Infill overlapping the frame

2.2.1 Doors with centre profile/horizontal ribbing

The spacer bush with a square hole is only used in doors with centre profile or horizontal ribbing.

2.2.2 Fitting the handle

- Always choose the pin setting (**a**, **b** or **c**) with the largest possible guidance for the interior handle.
- Shorten the pin of part ① if dimension **A** is less than 36 mm.

2.2.3 Fitting to the ceiling

⚠ CAUTION

Protruding anchor

There is a risk of injury when fitting to the ceiling without sufficient headroom.

- ▶ Shorten the anchor flush with the lower edge of the track.

2.2.4 Checking the door action and door stop

- ▶ Check the door action and door stop.

In order for the door to travel freely, the diagonal dimensions **a** and **b** must be equal and the rubber buffers in the end-of-travel position must contact the rear spacer on both sides.

To ensure simple and safe fitting, carefully go through the work steps illustrated in Figures 1 to 9.3!

2.3 Initial start-up

2.3.1 Checking the door spring tension (Figure 8.3)

- ▶ Open the door halfway.
The door should hold this position.

⚠ WARNING

Door spring tension

Improper adjustment of the door spring tension may result in injuries.

- ▶ Only have a specialist adjust the door spring tension in accordance with Figure 8.3 (1-4) when the door is open and secured.
- ▶ After adjusting the door spring tension, secure the spring holders with the spring securing pins.

If the door moves substantially downwards:

- ▶ Increase the spring tension.

If the door moves substantially upwards:

- ▶ Decrease the spring tension.

ENGLISH

Perform a test run and check the door in accordance with Chapter 4, *Inspection and Maintenance*.

When properly fitted and inspected, the garage door can be easily moved, is functionally safe and easy to operate.

3 Operation

3.1 Safety instructions

WARNING

Door travel

There is a risk of injury in the door's swivelling and opening area.

- ▶ When in operation, make sure that neither persons, children in particular, nor objects are located within the door's area of travel.
- ▶ Keep a safe distance of 1350 mm away from the door.

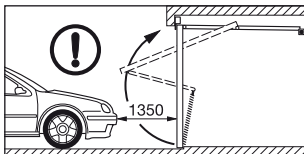

Opening and closing

There is a risk of injury when opening or closing the door improperly.

Manually opening:

- ▶ Only open the door with the exterior handle or interior handle, never with the lever arm or the cord knob.
- ▶ Always slide the door fully into the end-of-travel position and wait until the door has come to a stop.

Manually closing:

- ▶ Only close the door with the exterior handle, interior handle or the cord knob, never with the lever arm.
- ▶ Make sure that the locking engages correctly.

3.2 Opening the door with the handle

Opening from the outside:

- ▶ Turn the handle a quarter turn clockwise.

Opening from the inside:

- ▶ Turn the handle a quarter turn anti-clockwise.

The door is not locked when closed with the grip handle. Use the key or locking pin to lock the door.

3.3 Locking and unlocking the door

From outside with the key and from inside with the locking pin.

Unlocking from the outside:

- ▶ Turn the key one whole turn clockwise and remove the key.

Locking from the outside:

- ▶ Turn the key one whole turn anti-clockwise and remove the key.

Unlocking from the outside - self-locking:

1. Turn the key half a turn clockwise and slightly open the door.
2. Turn the key back to the original position and remove it.

When the door is closed, the lock is locked again.

Unlocking from inside:

- ▶ Push the locking pin to the left.

By unlocking in this way, you can then open the door without a key.

Locking from inside:

- ▶ Push the locking pin to the right.

NOTE:

- Follow the operator manufacturer's instructions for doors with operator.
- Ribbed steel doors with ventilation slots are locked horizontally with non-resilient rods. The locking pin is concealed to prevent burglary.

4 Inspection and Maintenance

4.1 Safety instructions

- ▶ Have a specialist perform inspection and maintenance work on the door at least once a year in accordance with these instructions.

⚠ WARNING**Door travel**

There is a risk of injury in the door's swivelling and opening area.

- ▶ When in operation, make sure that neither persons, children in particular, nor objects are located within the door's area of travel.
- ▶ Functional parts, particularly safety components, may only be exchanged by a specialist.

4.2 Checking the condition of the door

- ▶ Visually inspect the general condition of the door, all components, and safety devices for completeness, proper condition, and effectiveness.
- ▶ Check that all of the fixing points are tight. Tighten the screws if necessary.
- ▶ Lubricate all pivot points with a standard penetrating or lube oil. Do not use grease (see Figure 8.1).

4.3 Checking the door spring tension

See Chapter 2, *Fitting and Initial Start-Up*.

4.4 Replacing the door tension springs

- ▶ Have the door tension springs replaced by a specialist after approx. 25,000 door cycles.

This is required at the following approximate time:

Door cycles per day	Period	
Up to 5	Every	15 years
6 – 10	Every	8 years
11 – 20	Every	4 years
21 – 40	Every	2 years
Over 40		yearly

CAUTION

Elongated door tension spring

Danger of injury due to elongated door tension spring – the coil spacing is irregular.

- ▶ Call in a qualified specialist to replace the door tension spring immediately.

4.5 Checking the track rollers and tracks

- ▶ Clean the tracks. Do not apply grease.
- ▶ Check the track rollers for wear. Have the track rollers replaced by a specialist if they are greatly worn or damaged.

4.6 Checking the lock and locking mechanism

ATTENTION

Care products

Unsuitable care products may cause damage.

- ▶ Only use specialised care products for the profile cylinder. Do not use oil or graphite.

- ▶ Lubricate the locking rotary catch with a standard penetrating or lube oil. Do not use grease.

- ▶ Check the locking as shown in Figure 1.2 and adjust it if necessary.

4.6.1 Adjusting the latching (Figure 9.1)

The latching has already been adjusted for normal use. In case of building structure imprecision:

- ▶ Loosen the nuts, slide the latching in the direction of the arrow and tighten the nuts again.

4.7 Accessories

- To ensure a high level of quality, safety, reliability, as well as a long service life, only use original parts intended for this particular garage door.
- Only use an operator approved for the garage door according to EN 13241-1. Follow the separate instructions for fitting and operation provided by the operator manufacturer. Immobilise both rotary catches.
- Use the latching kit for up-and-over doors if you want the rotary catches to function when operating a garage door operator.

5 Surface Protection

5.1 Door with steel infill

The door leaf is made of galvanized material and has a polyester-primer coating. Scratches or minor damage are no reason for complaints. For long-lasting surface

protection, we recommend applying a final coat within three months of delivery. For this, follow the steps below:

1. Lightly sand the door surface with a fine sand paper (at least 180 grain size).
2. Clean the door surface with water and then dry it.
3. Apply a 2K-EPOXY-etch primer to the door surface and paint it with a conventional synthetic resin paint for outdoor applications. Coordinate both coatings with each other. When doing so, follow the instructions provided by the paint manufacturer.

Renew the final coat when necessary, depending on the local weather conditions.

5.2 Door with timber or GRP infill

See separate instructionlabel on inside face of door.

6 Cleaning and Care

6.1 Door surfaces made of steel

- ▶ Clean the door surfaces with clear water and a soft sponge or with conventional paint cleaners.

6.2 Synthetic panes

ATTENTION

Cleaning products

Unsuitable cleaning products can cause stress cracks and damage the panes.

- ▶ Do not use any abrasive cleaners, sharp tools or alcohol-based glass cleaners.

- ▶ Clean the synthetic panes with clear water and a soft sponge or cloth.
- ▶ Use a mild, acrylic-compatible plastics cleaner if more heavily soiled. Follow the instructions for use provided by the manufacturer.

6.3 Data plate

- ▶ Clean the data plate.
It must always be easy to read.

7 Assistance with Malfunctions

If the door is difficult to move or exhibits other malfunctions:

- ▶ Check all the functional parts. To do this, please follow the instructions in Chapter 4, *Inspection and Maintenance*.
- ▶ In the case of uncertainty, contact a specialist for assistance.

8 Dismantling

Have the door dismantled and disposed of by a specialist.

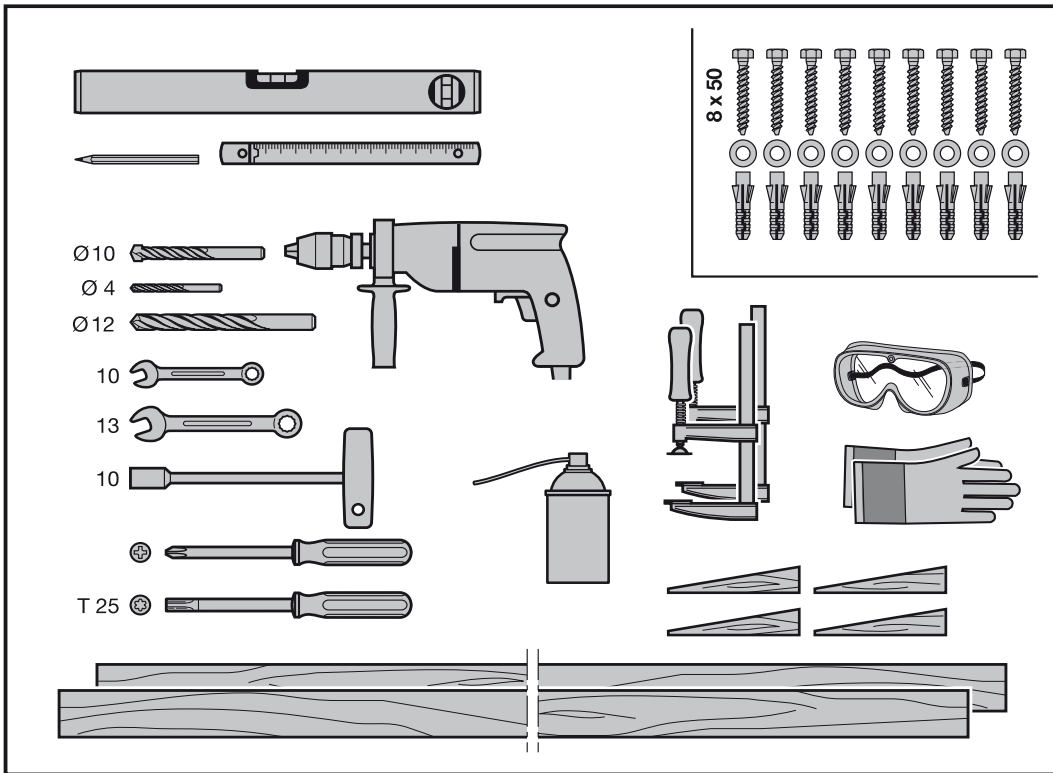

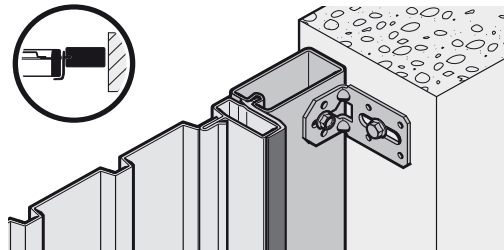
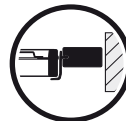
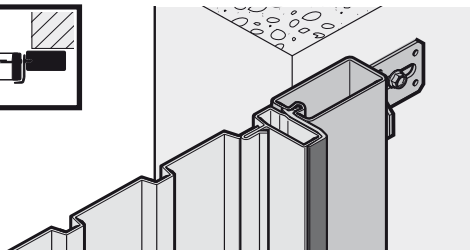
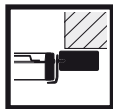

- I**
- II**
- 1**
- 2**
- 3**
- 4**
- 5**
- 6**
- 7**
- 8**
- 9**

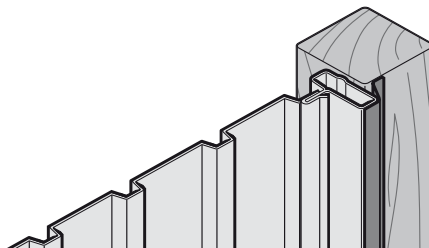

- III**
- IV**
- 10**
- 11**
- 12**
- 13**
- 14**
- 15**
- 16**
- 17**
- 18**

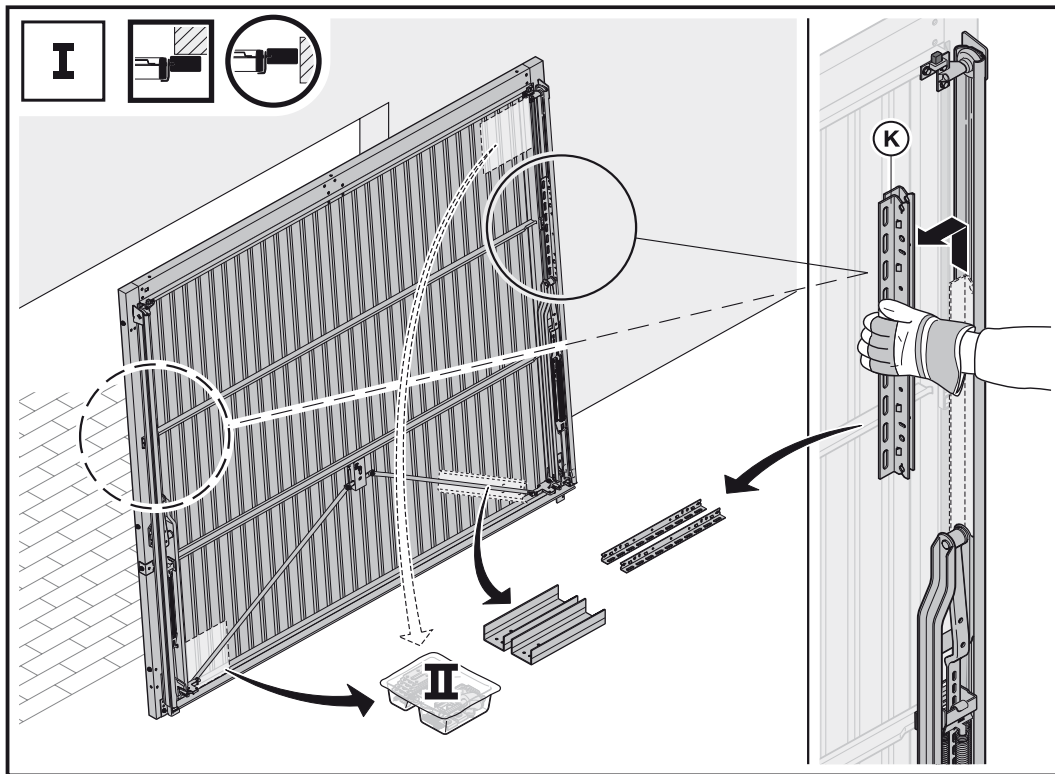

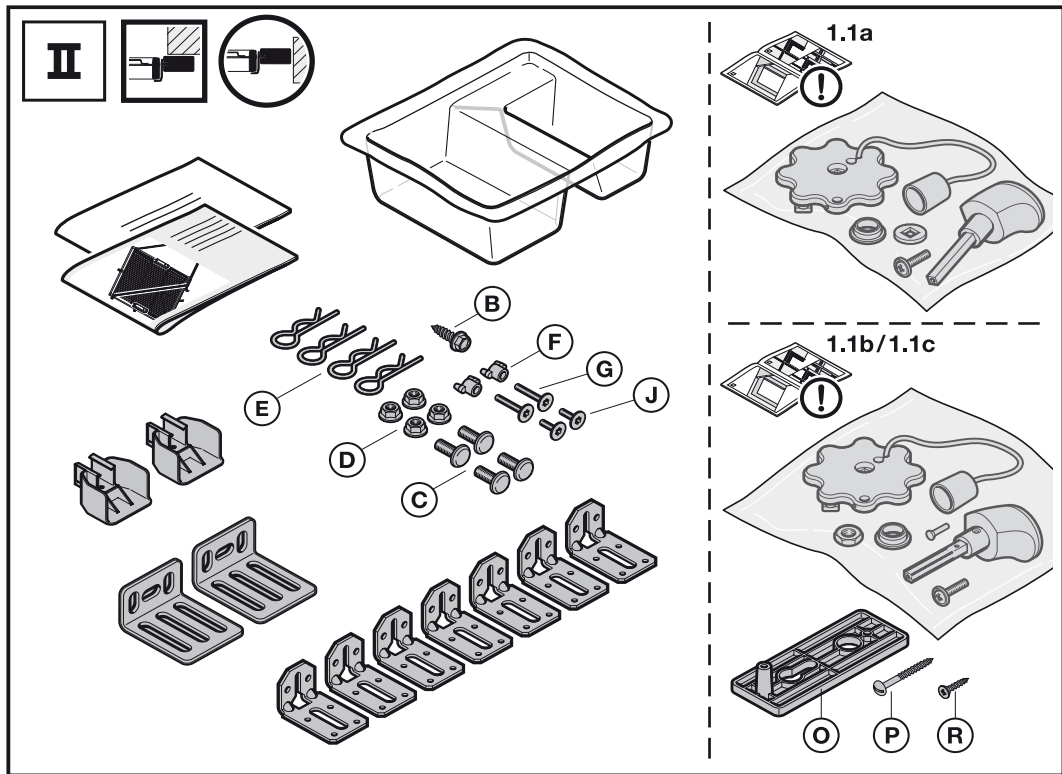

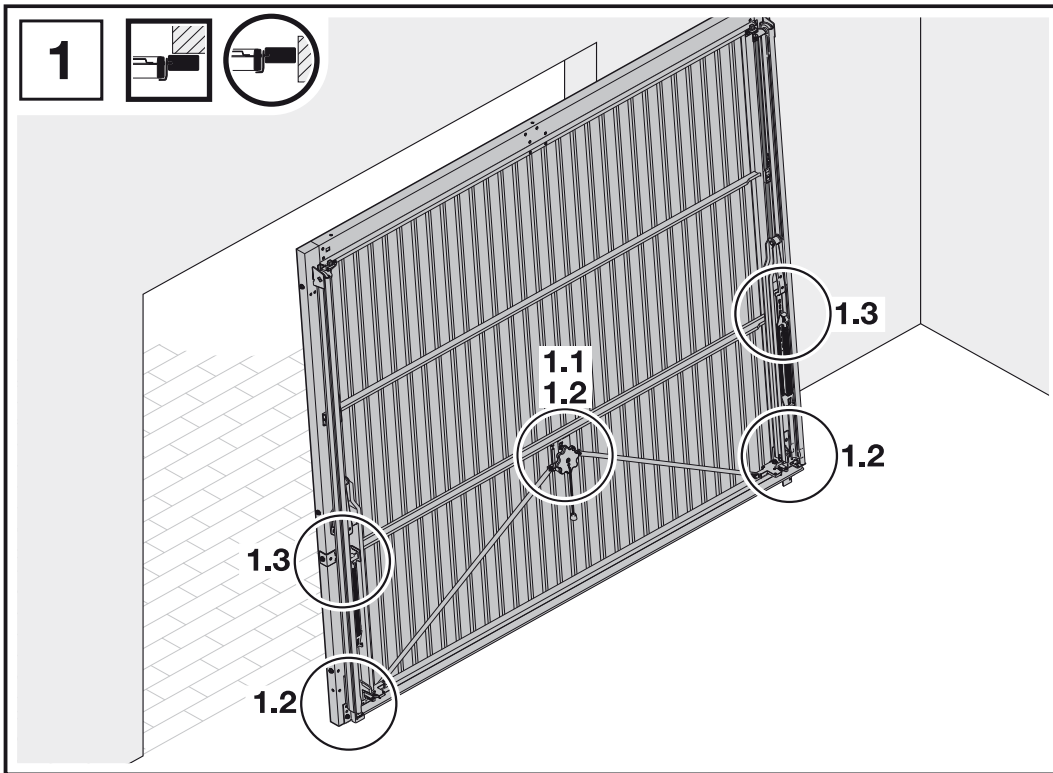

1.1a

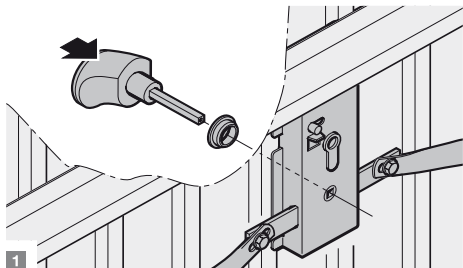
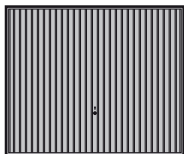

2.2.1

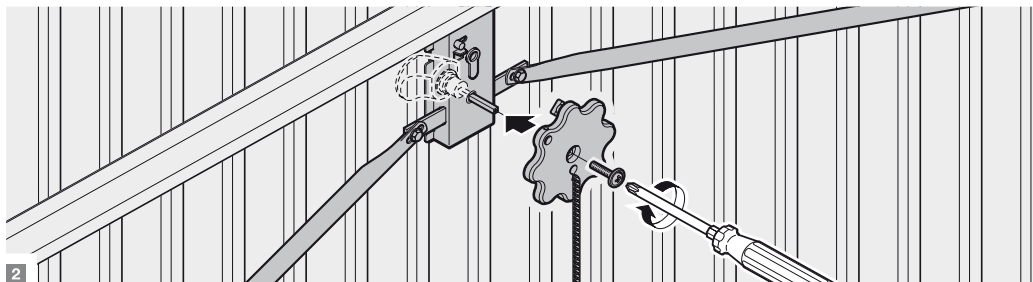
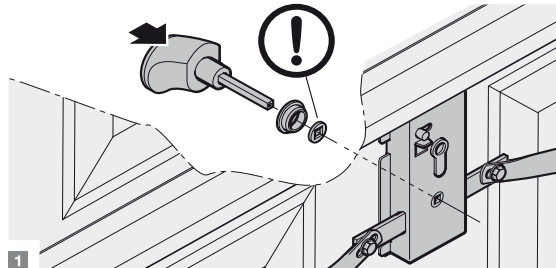
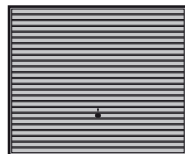
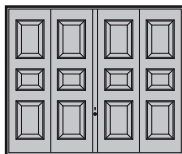

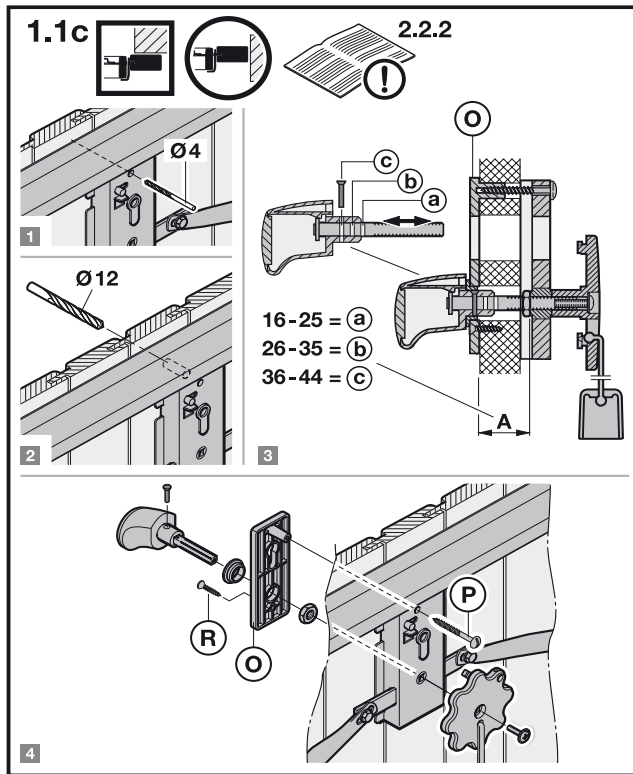
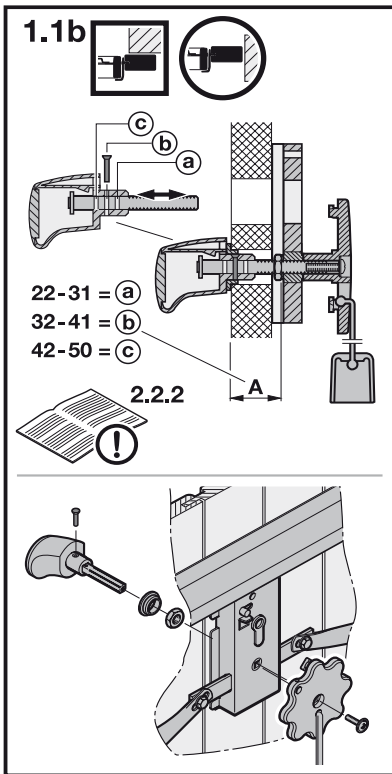

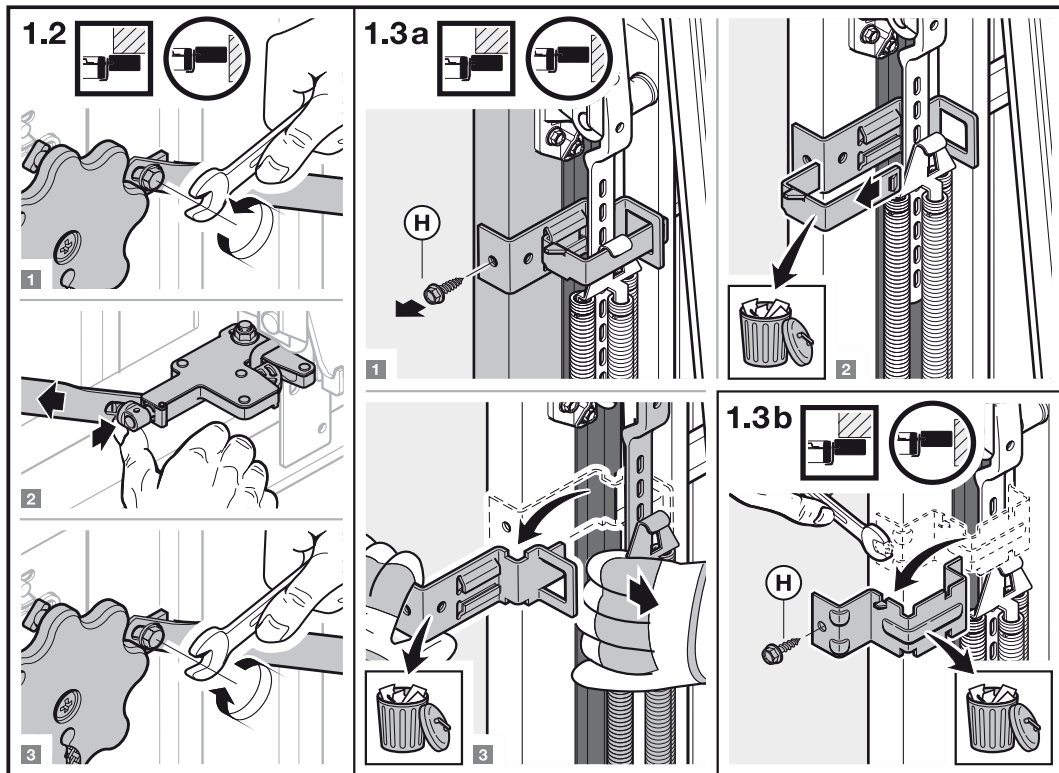

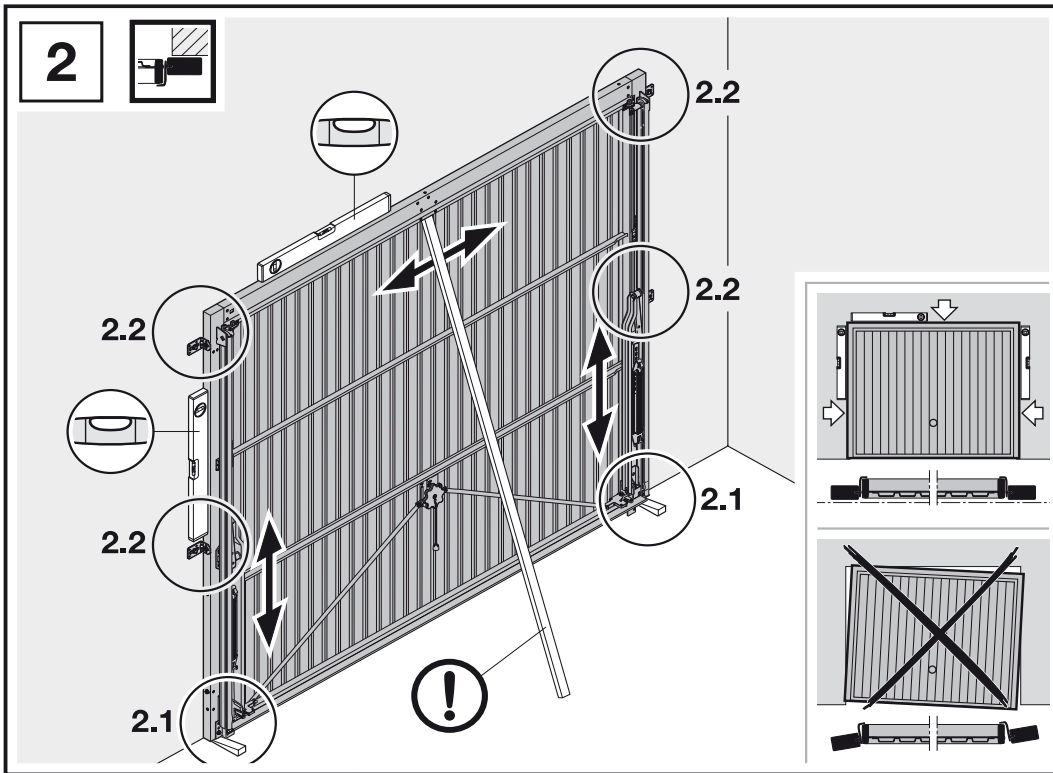

2.1

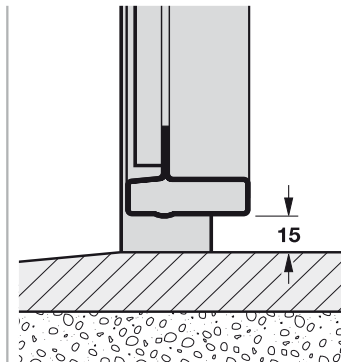
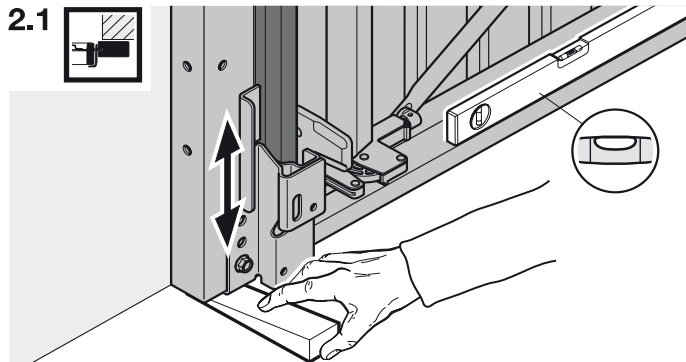

2.2

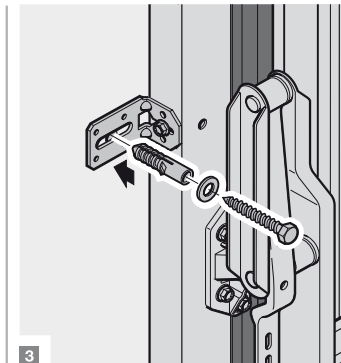
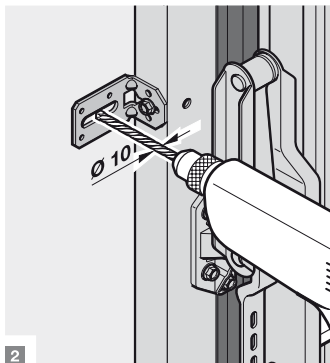
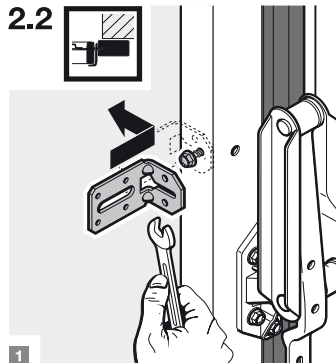

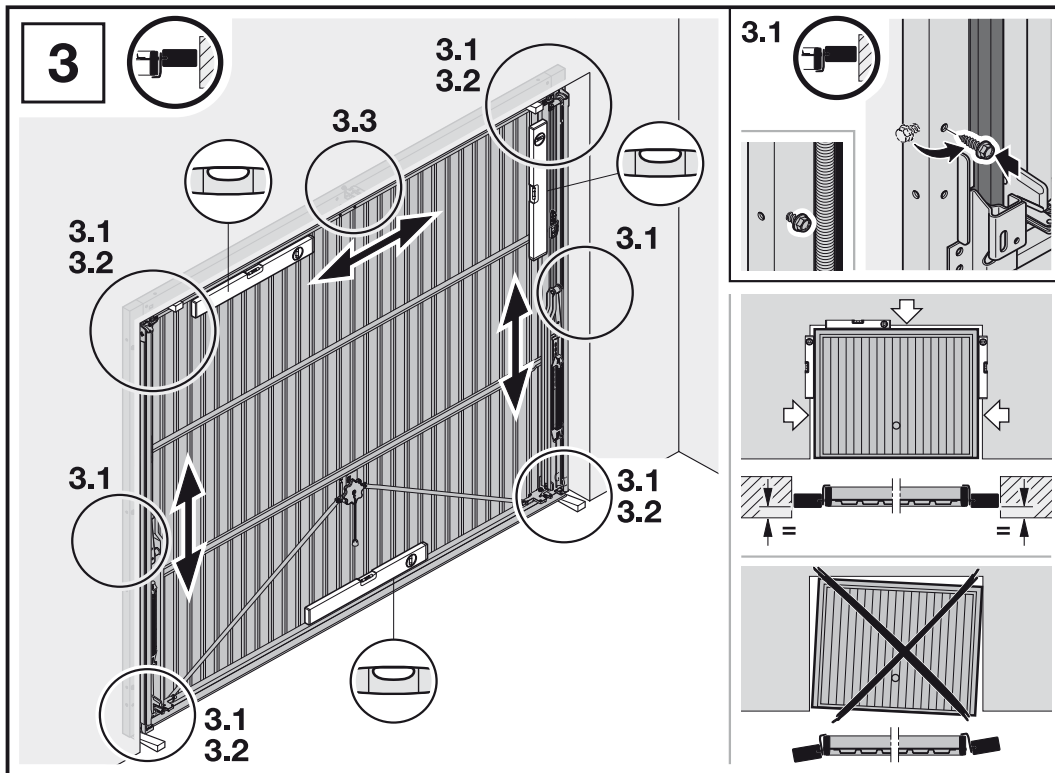

3.2

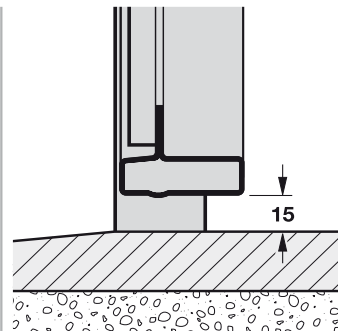
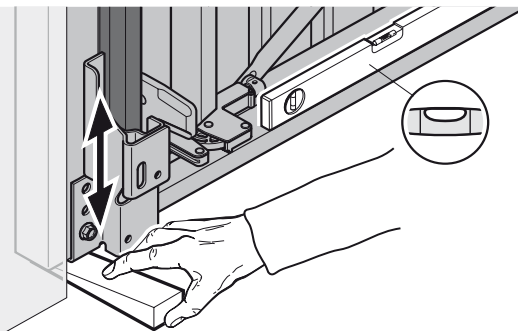

3.3

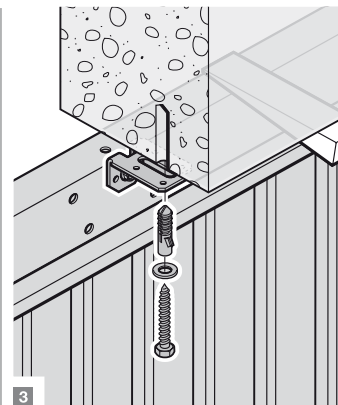
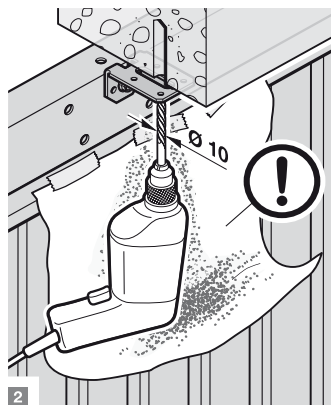
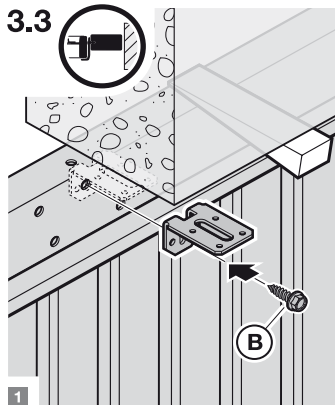

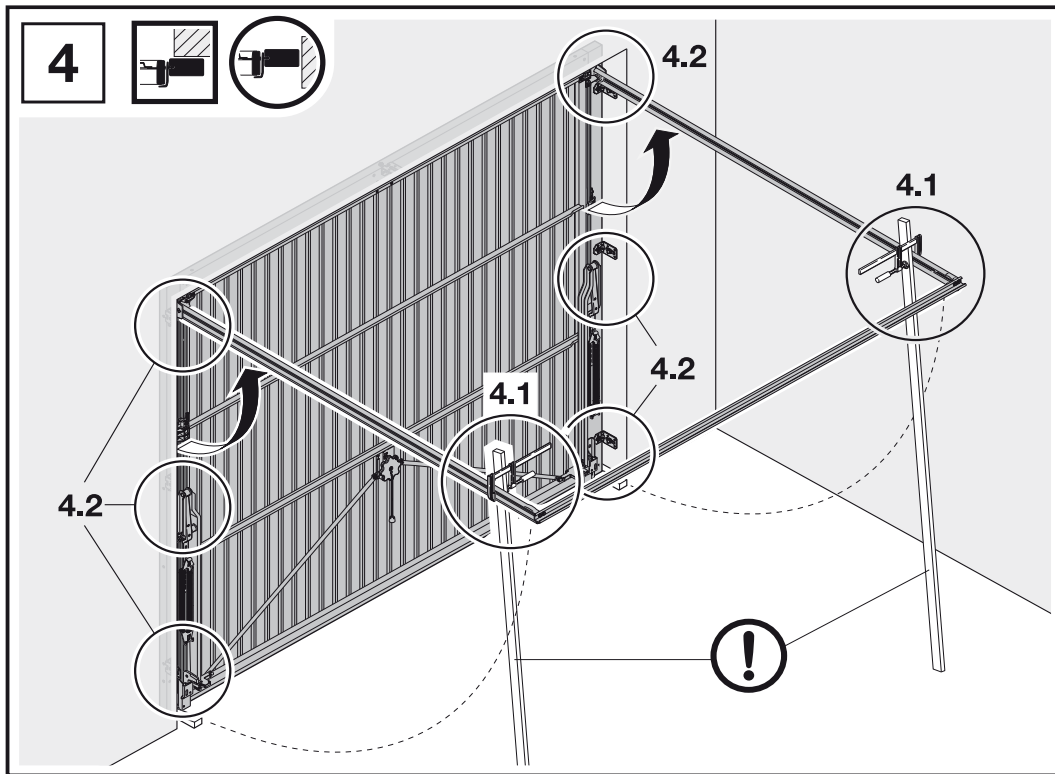

4.1

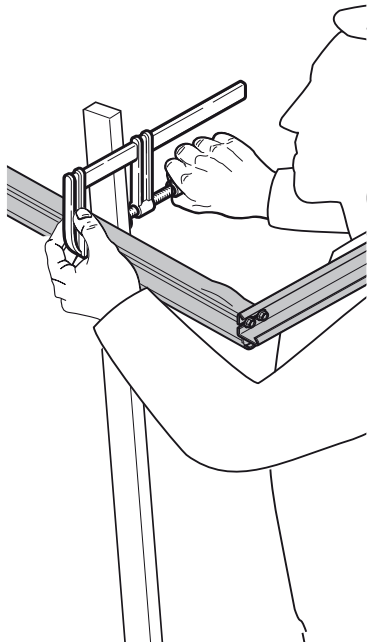

4.2

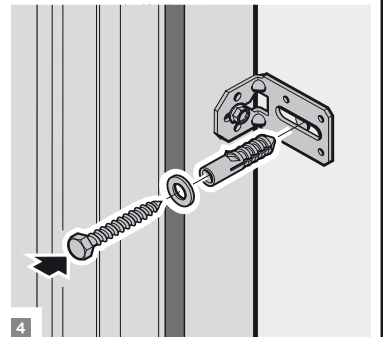
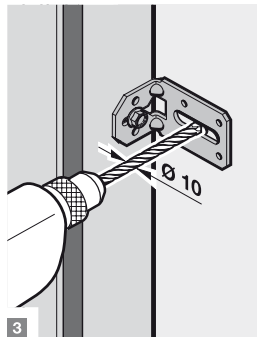
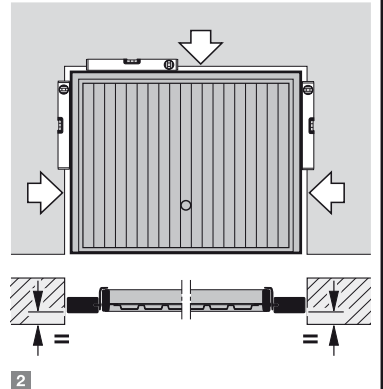
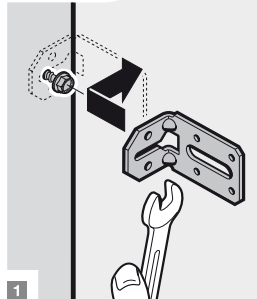

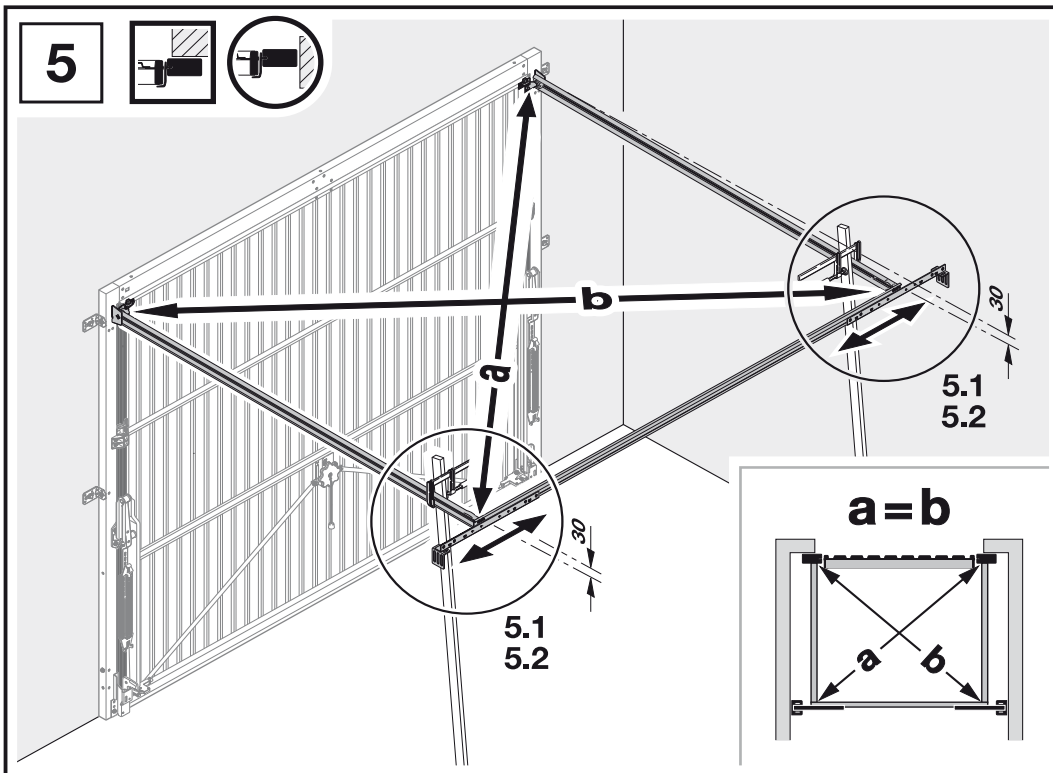

5.1

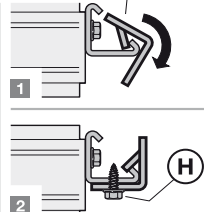
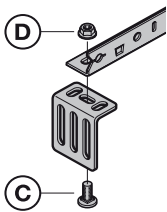
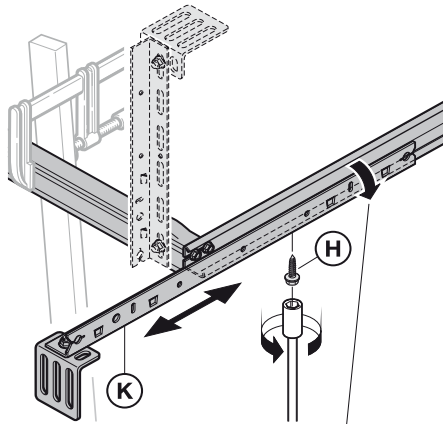

5.2a



2.2.3

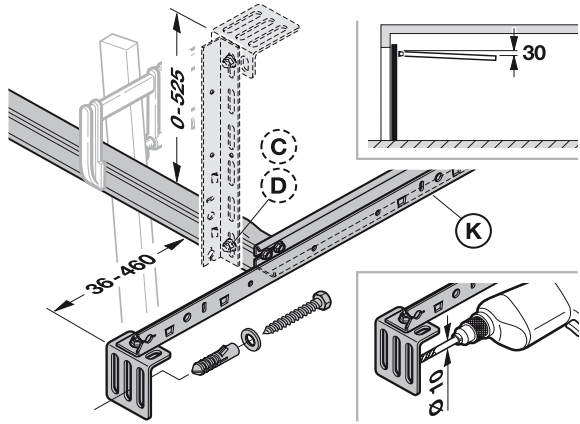

5.2b

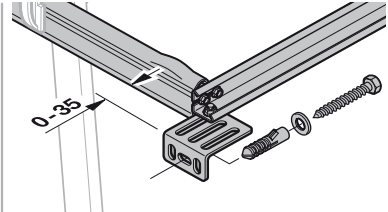
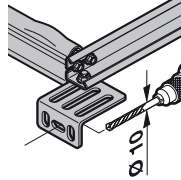

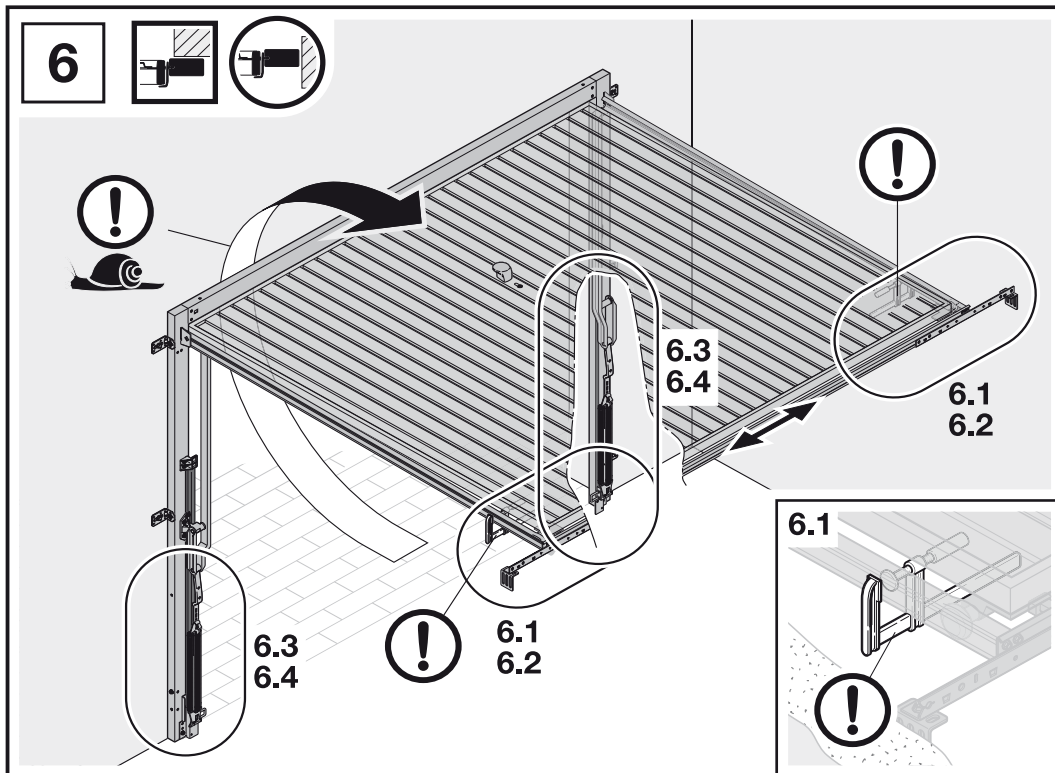

6.2



2.2.4

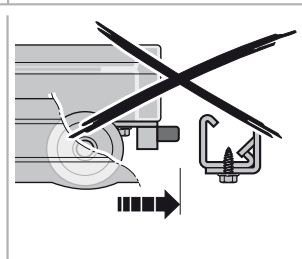
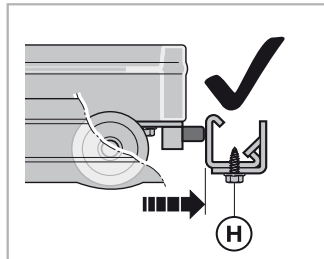
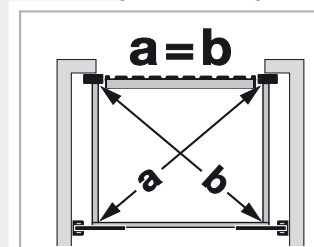
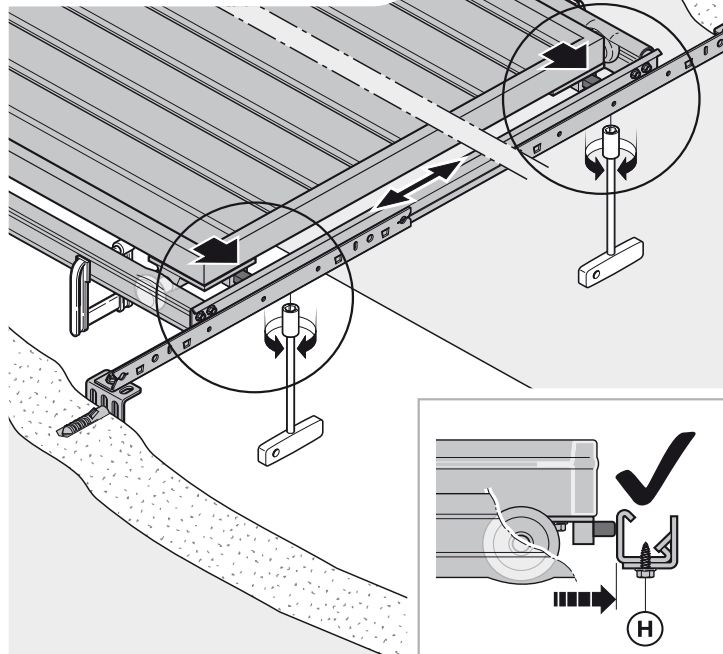

6.3

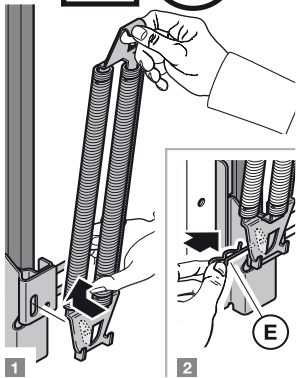

6.4

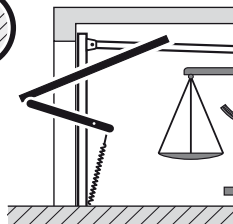
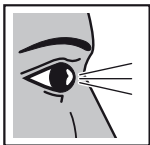

2.3.1

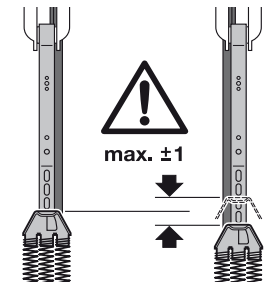
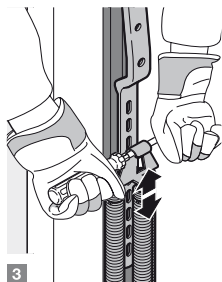
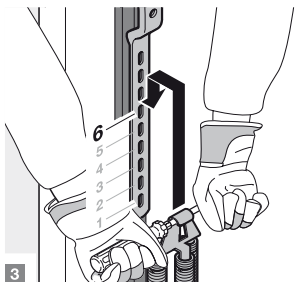
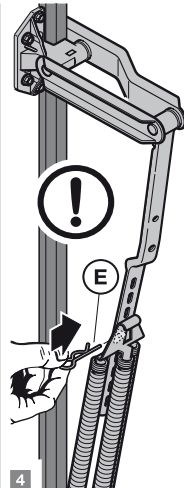
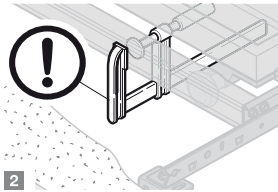
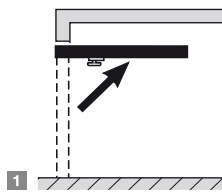

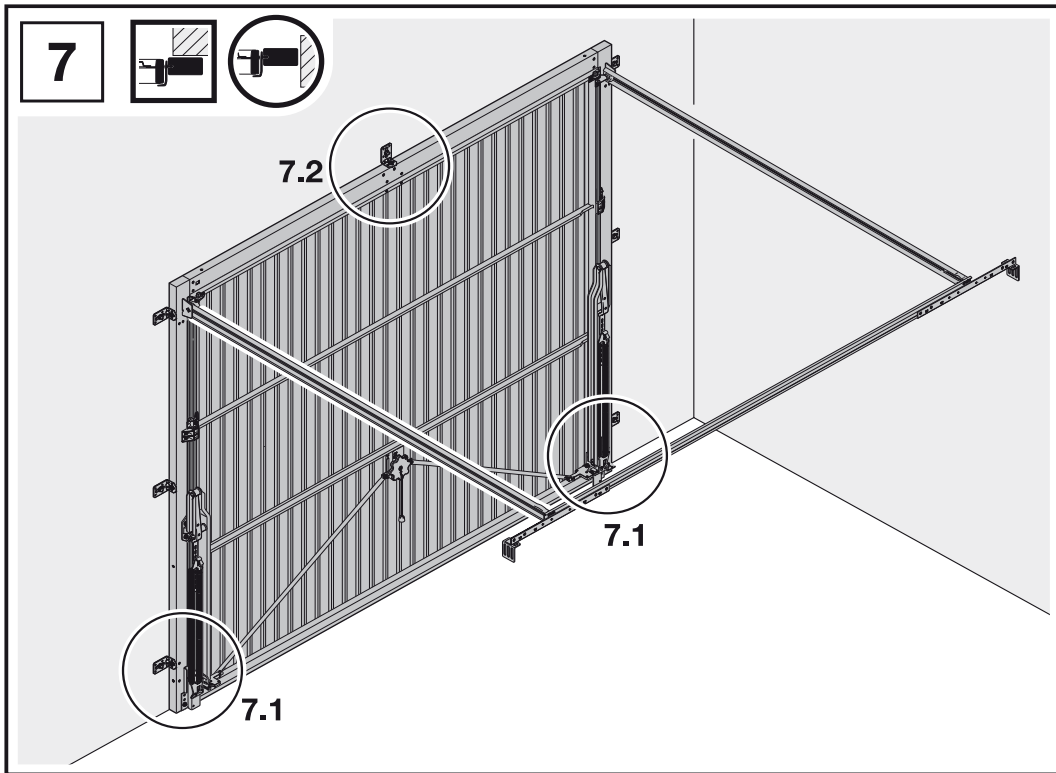

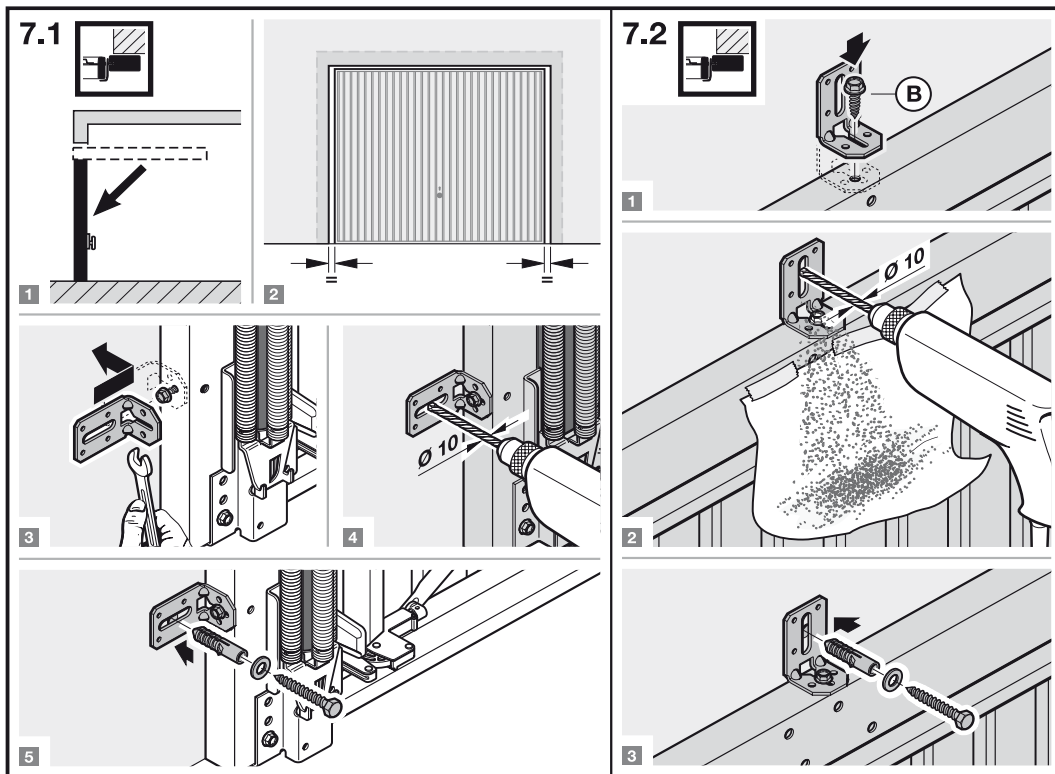

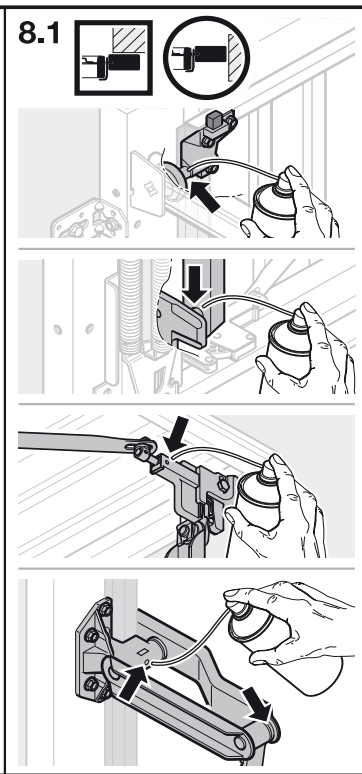
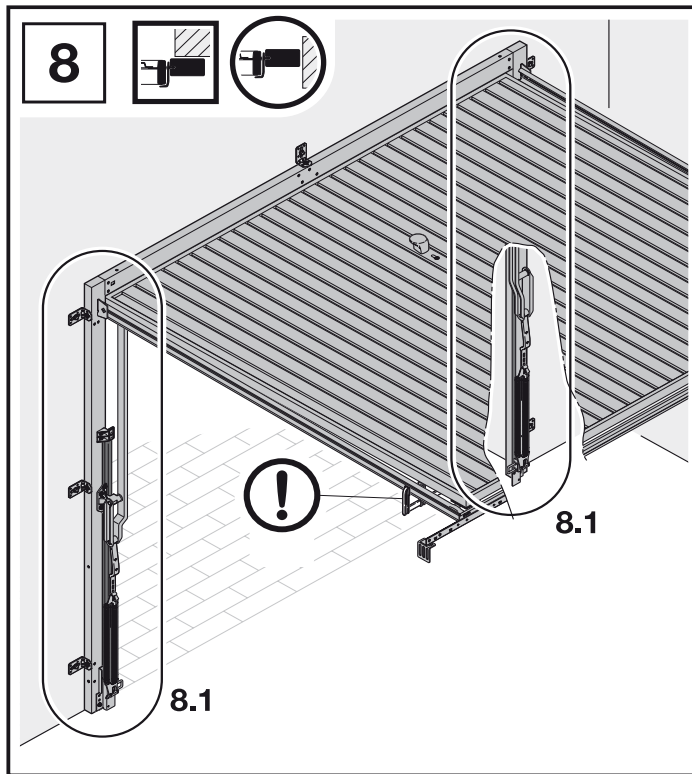

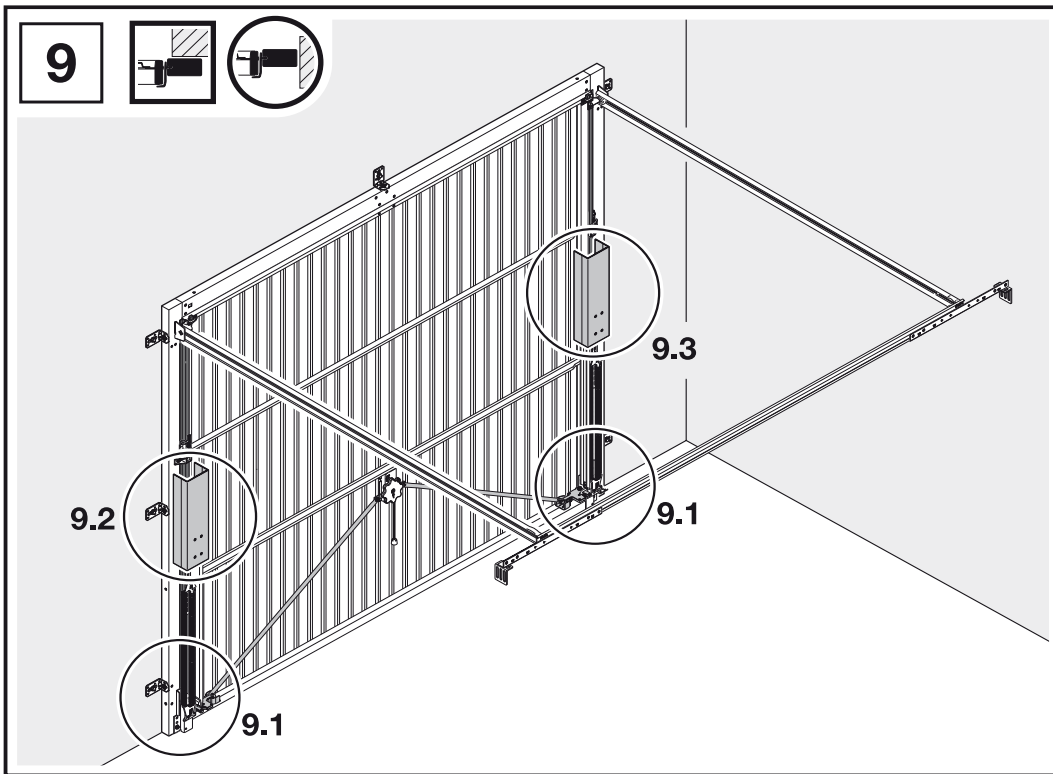

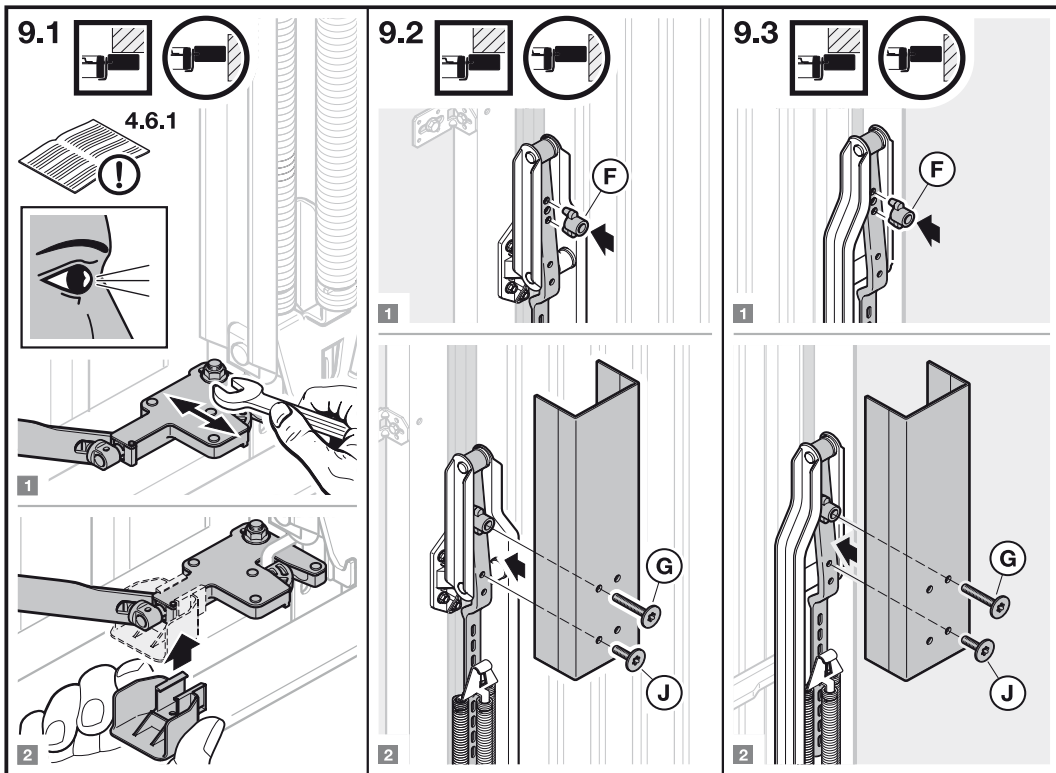

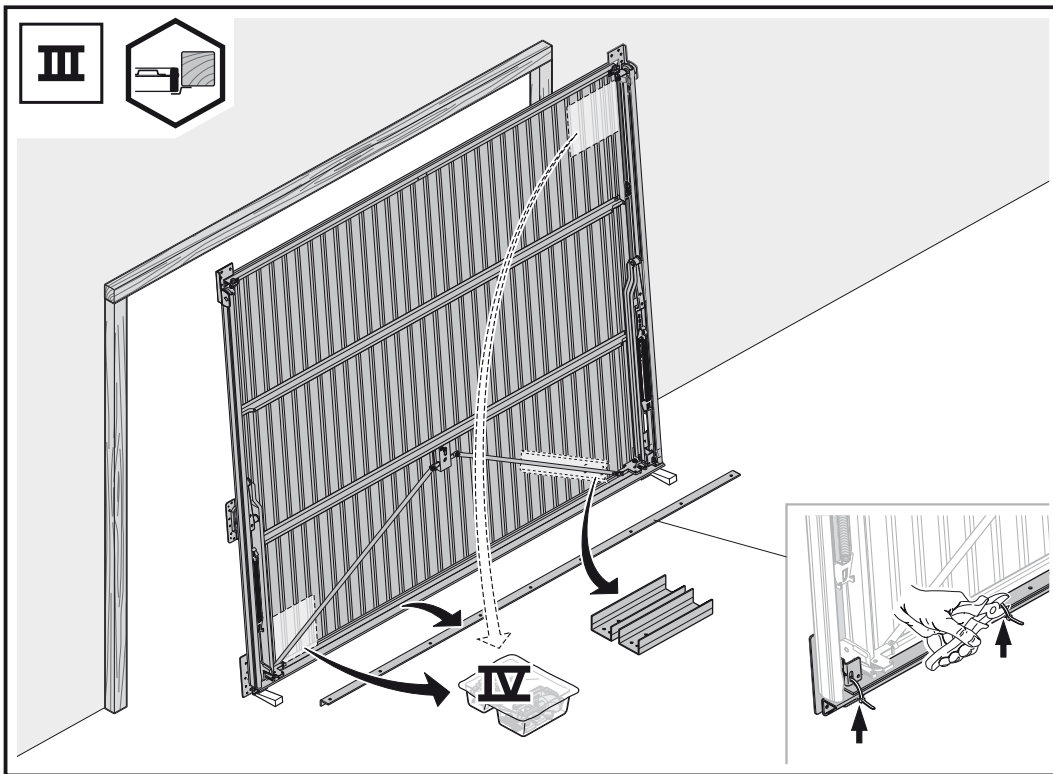

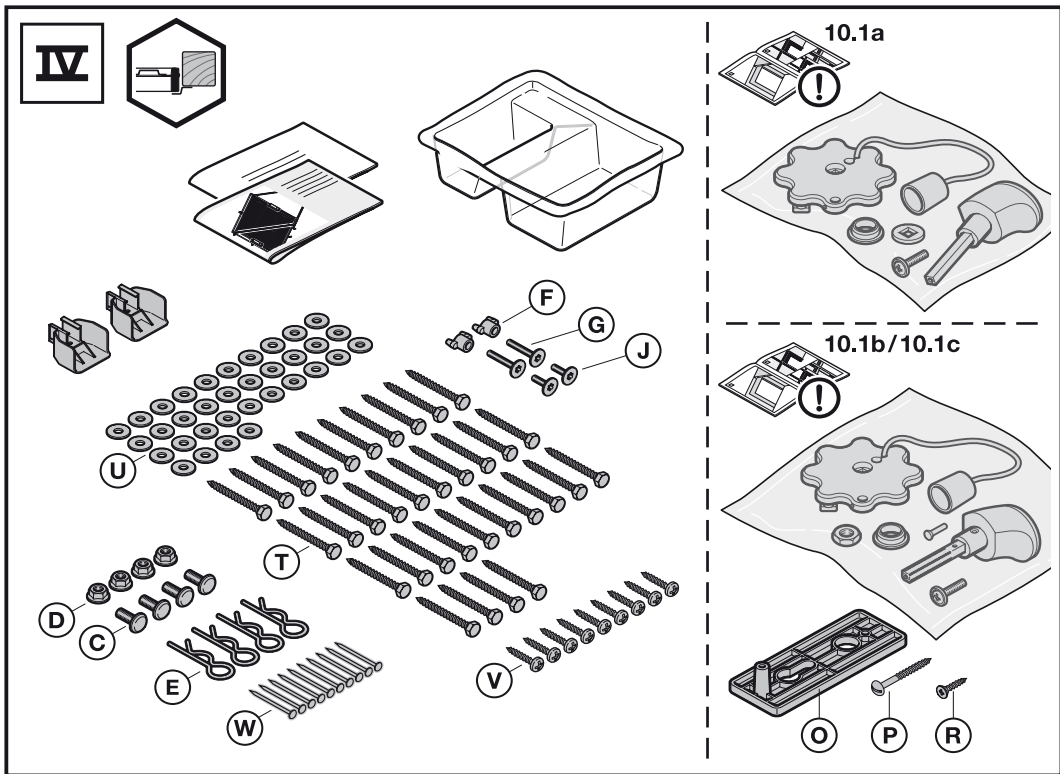

10

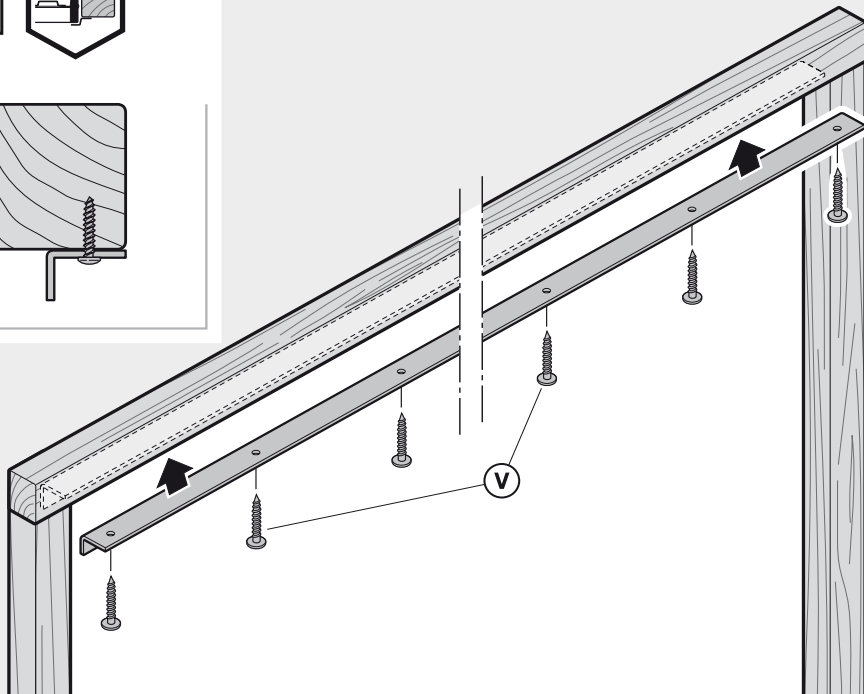
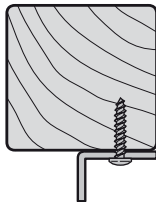

11

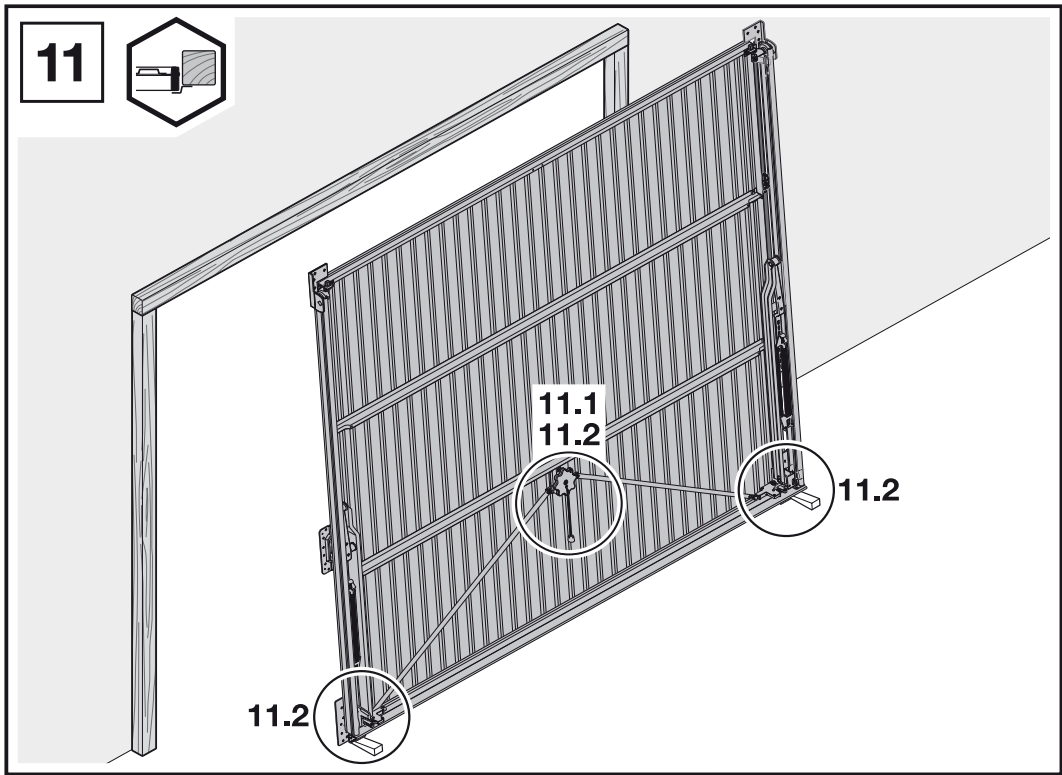

11.1a

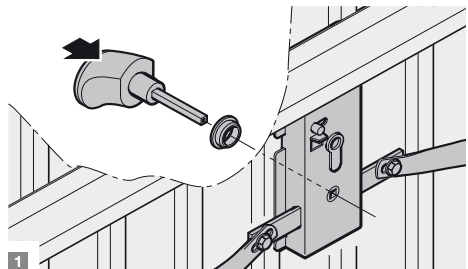
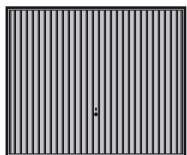

2.2.1

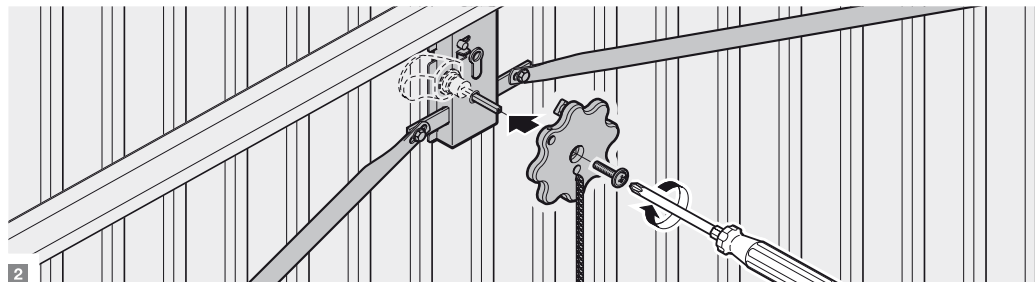
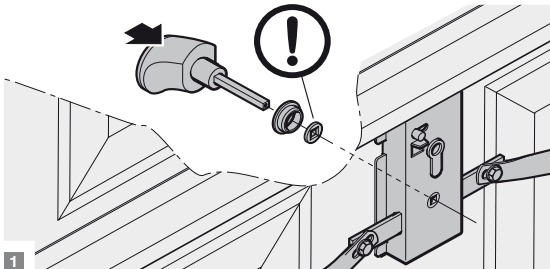

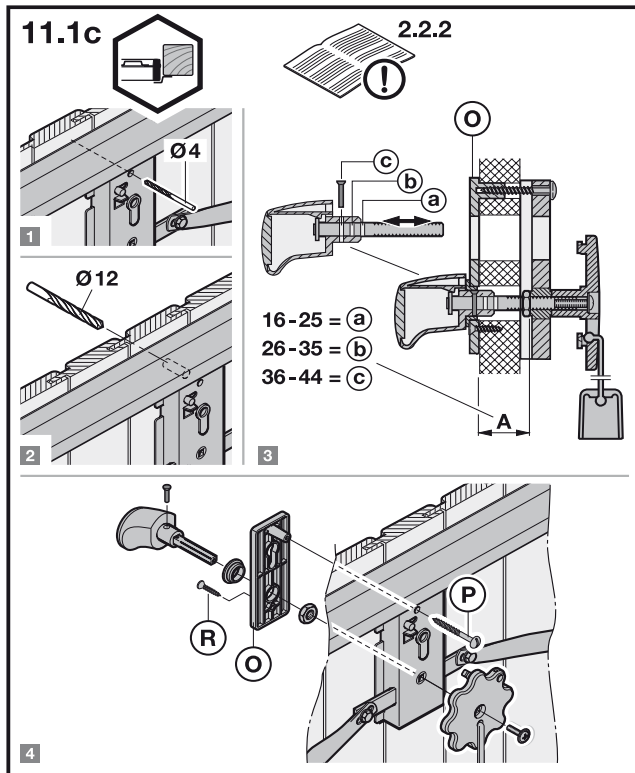
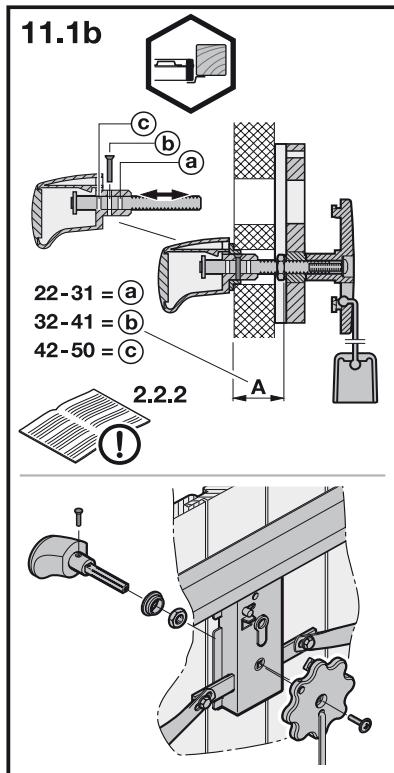

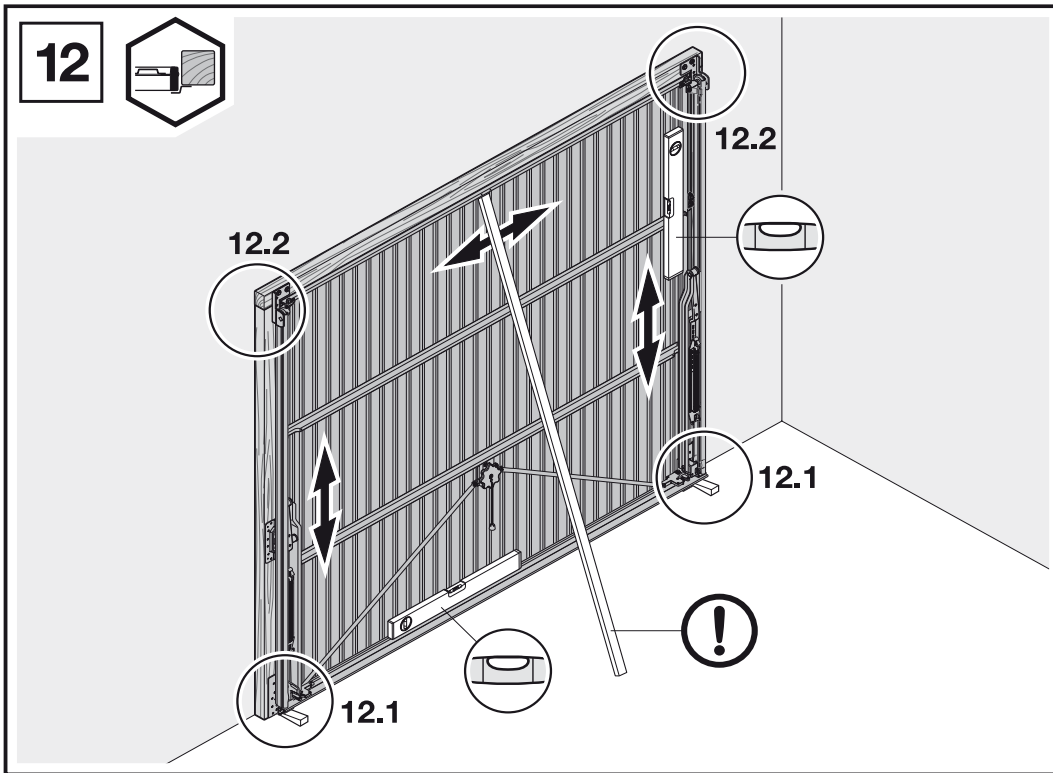

12.1

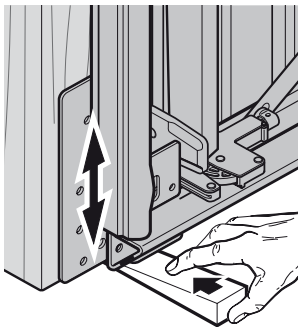
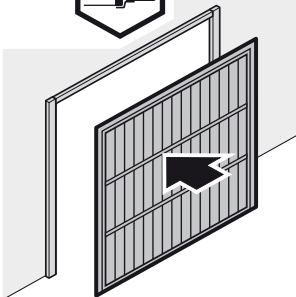

1

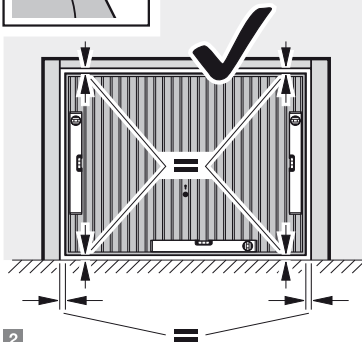
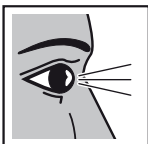

2

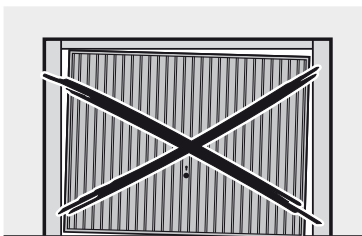

12.2

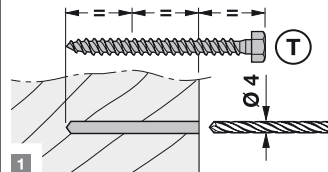
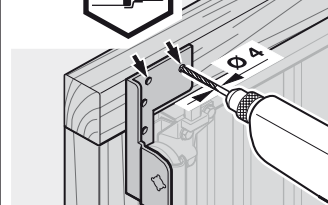

1

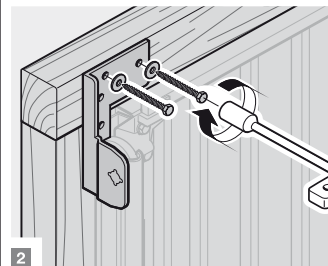

2

13

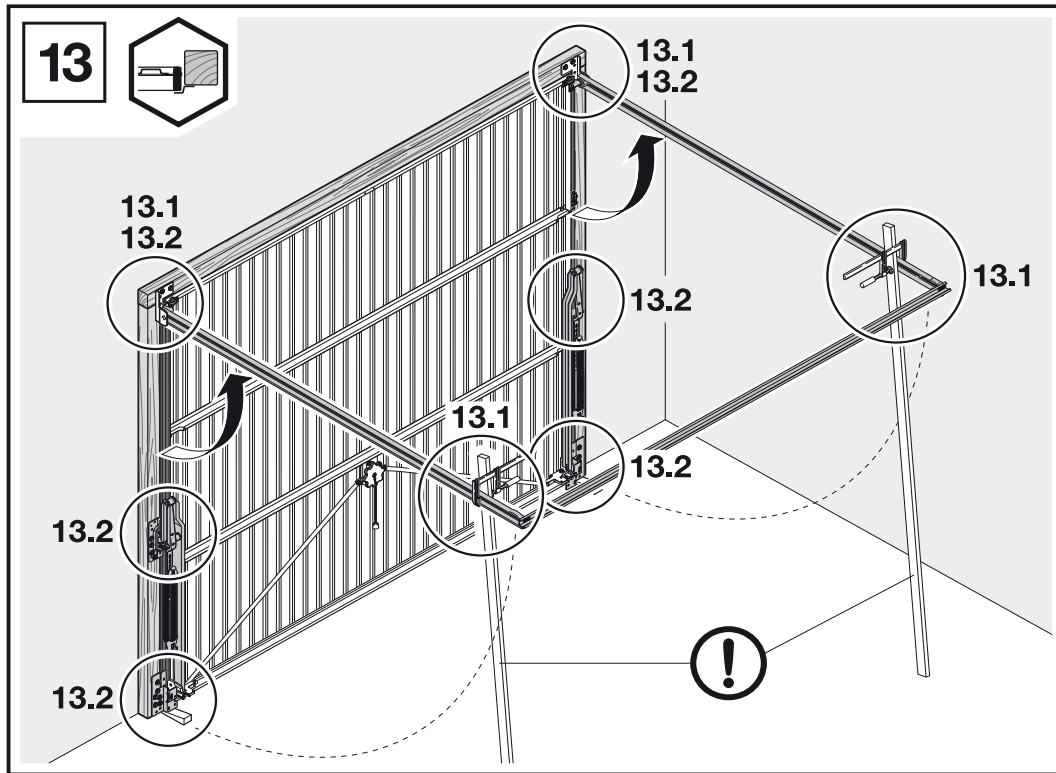

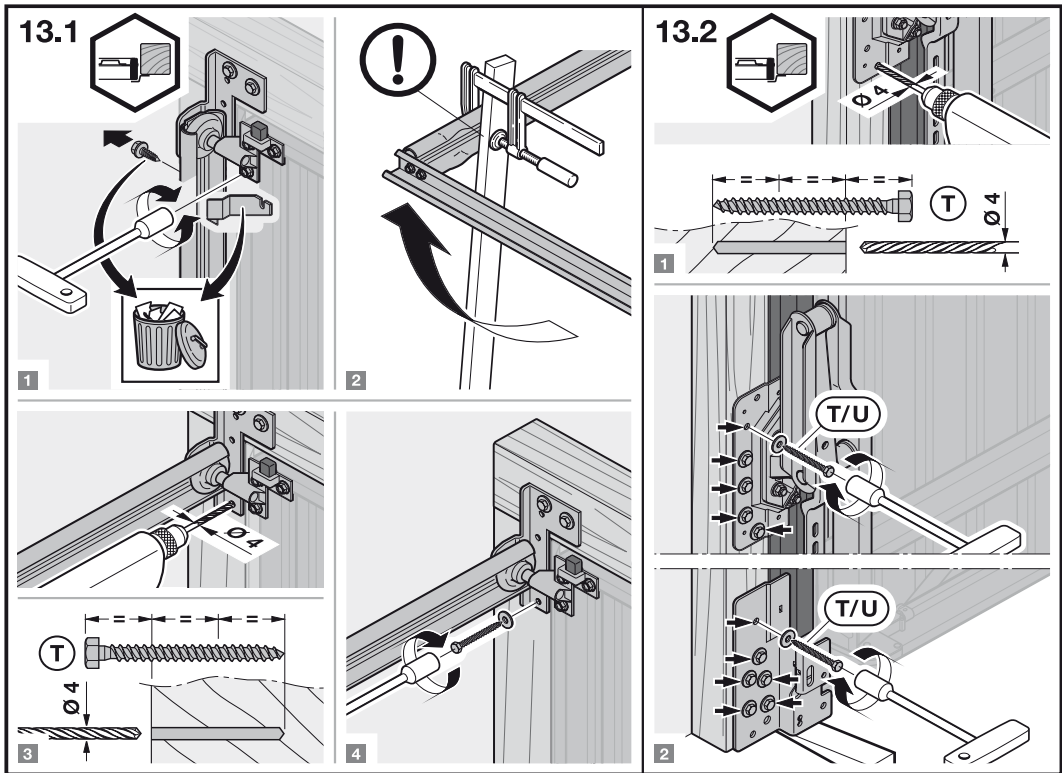

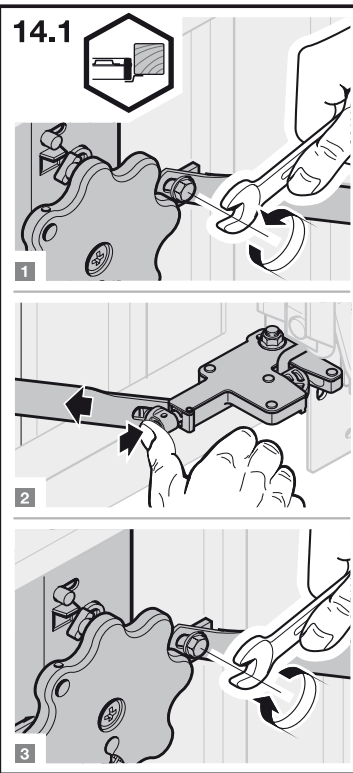
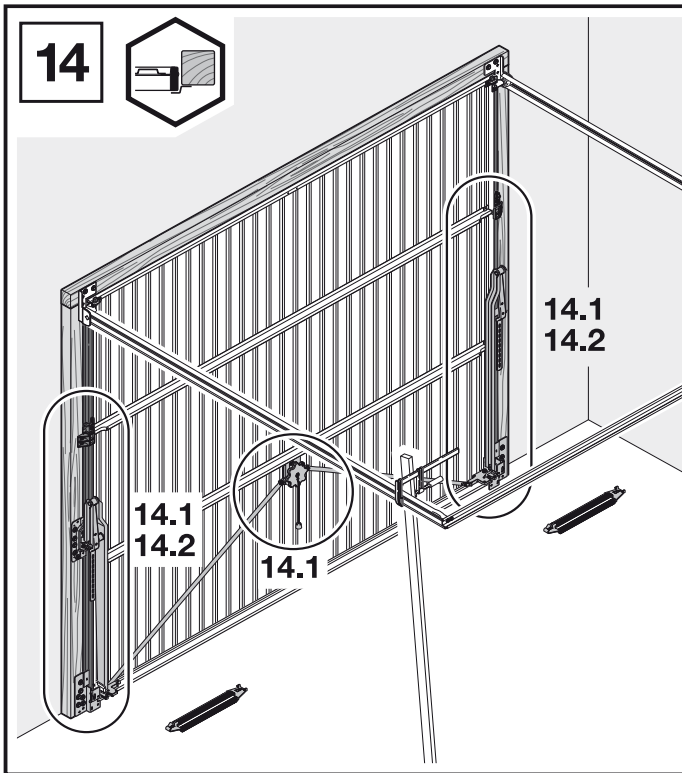

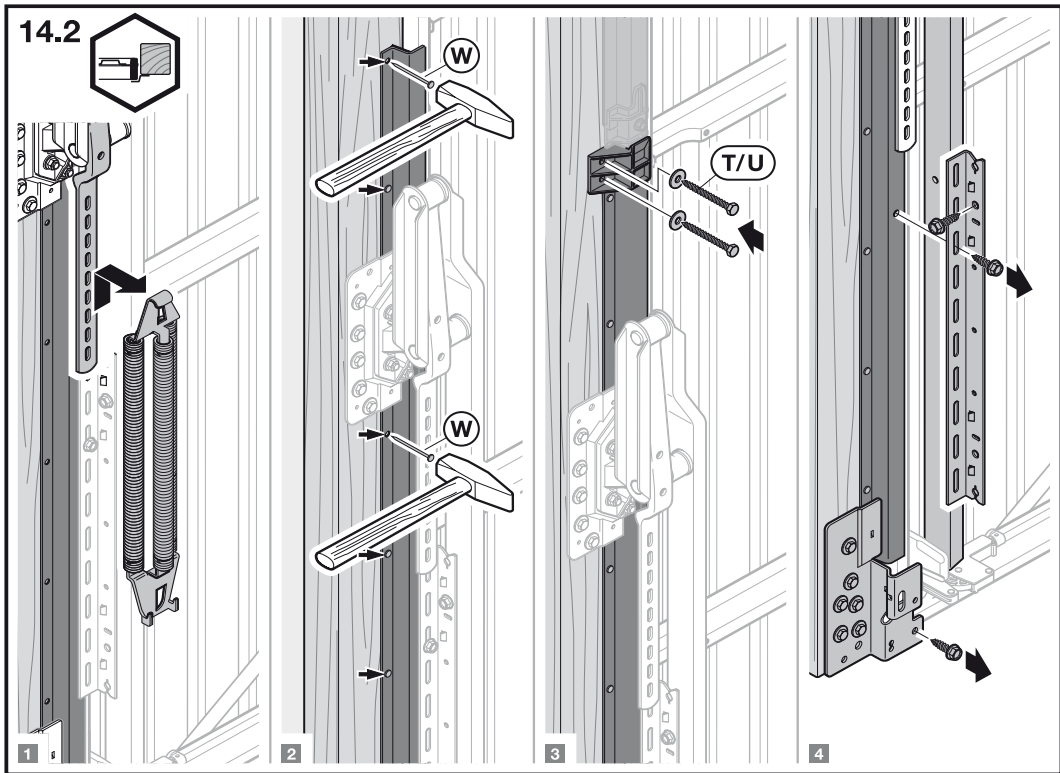

15

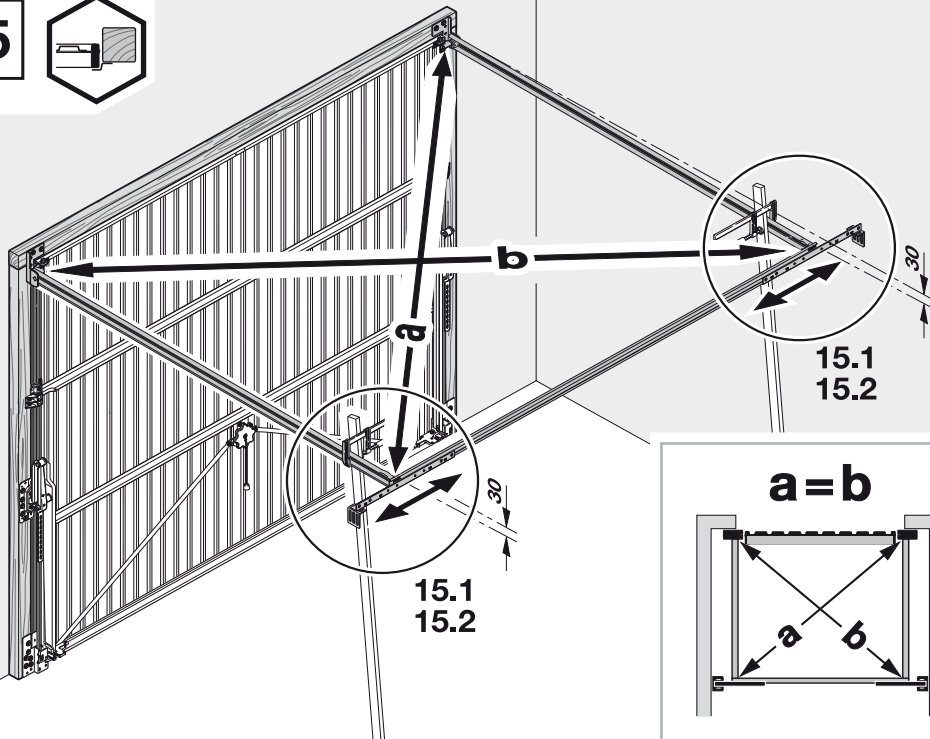

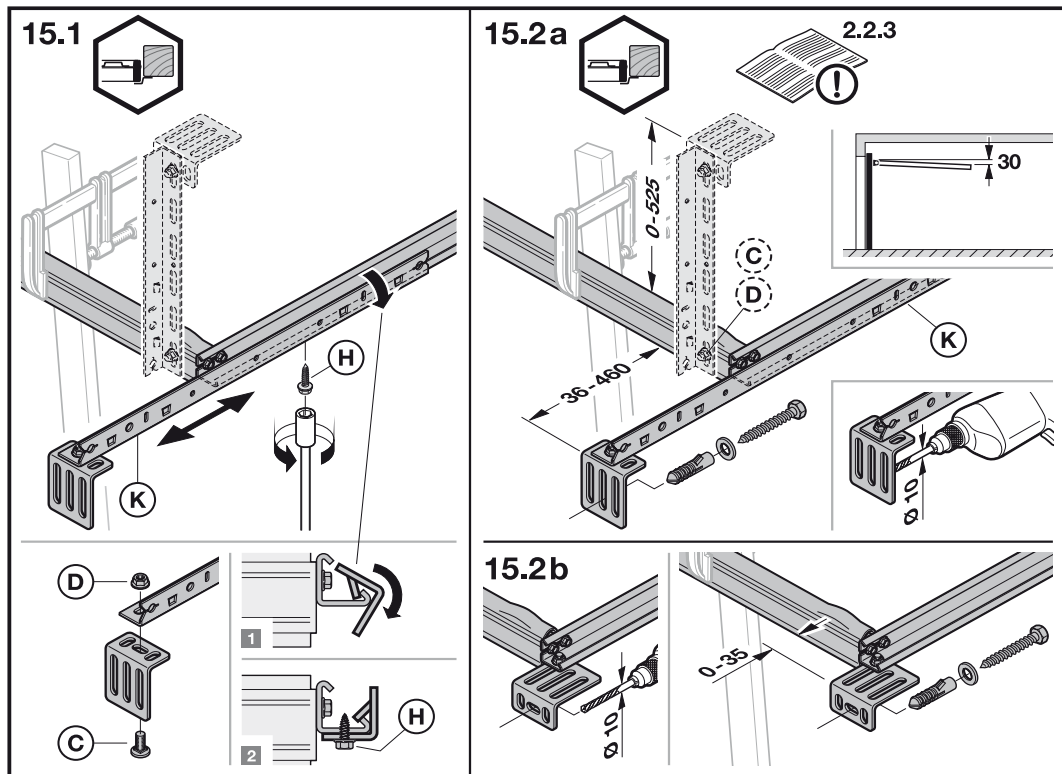

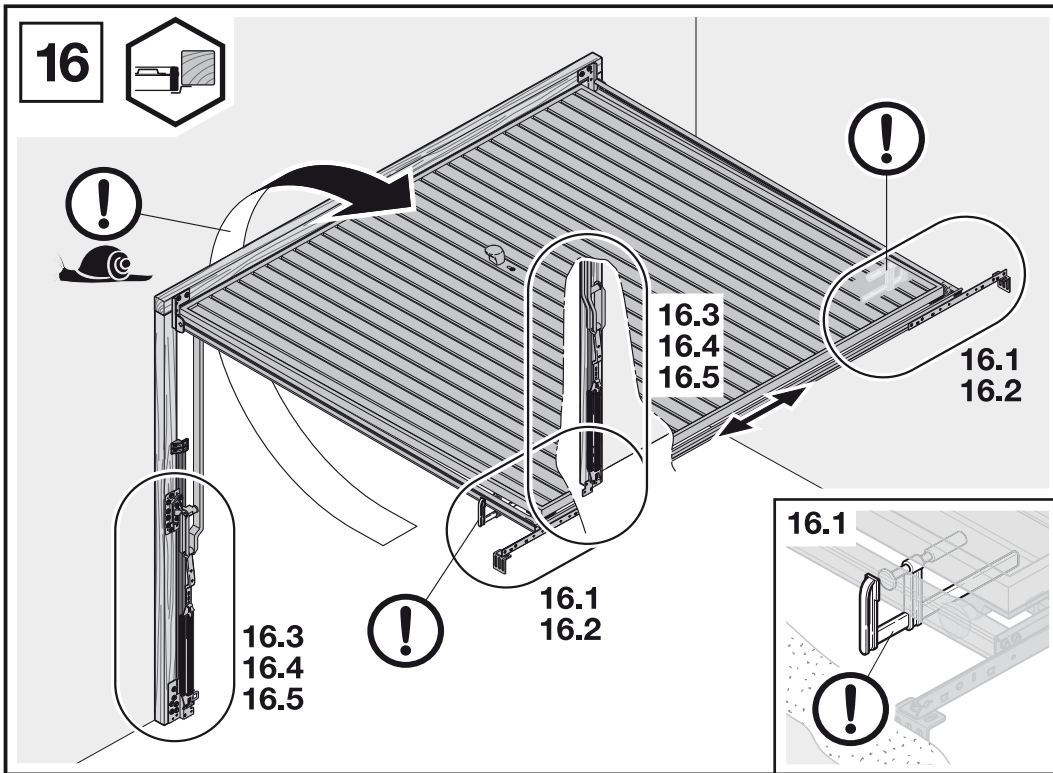

16.2



2.2.4

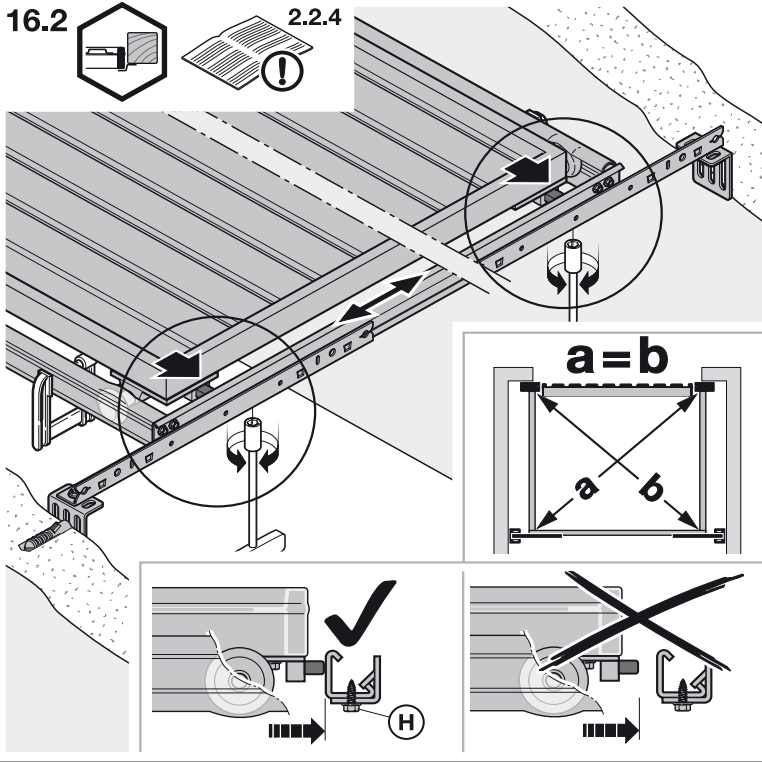

16.3

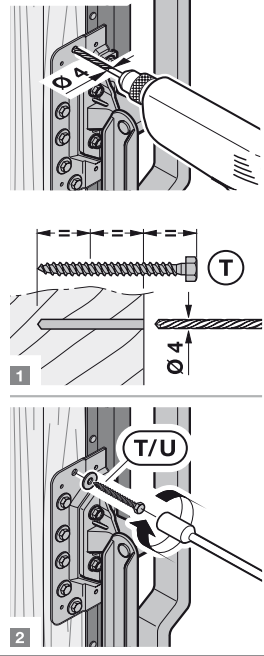

16.4

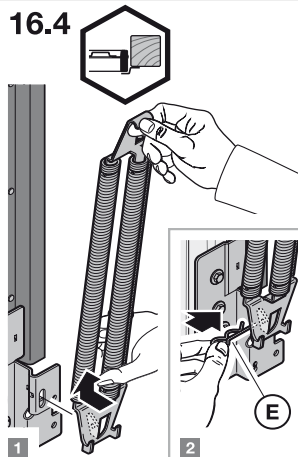

1

2

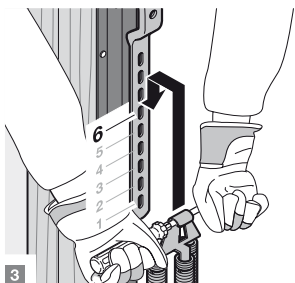

3

16.5

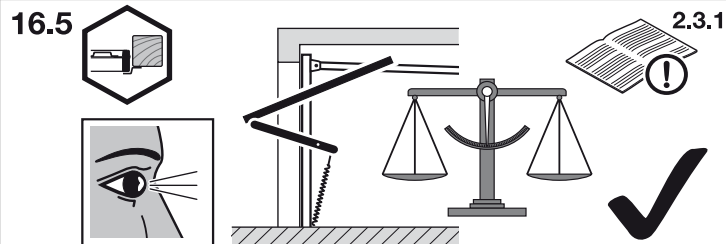

1

2

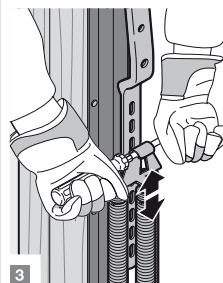

3

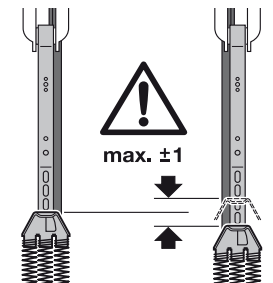

max. ±1

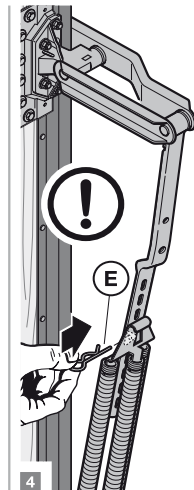

4

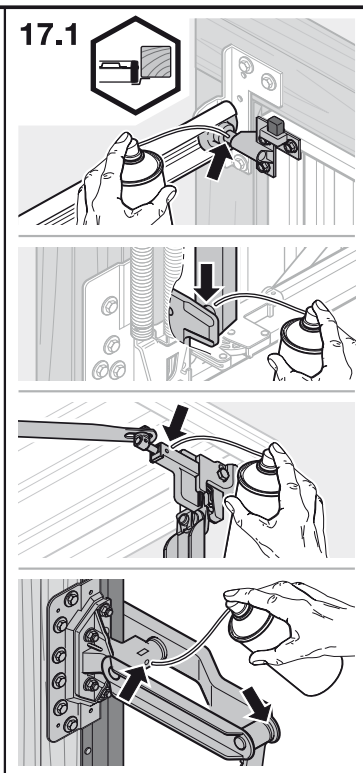
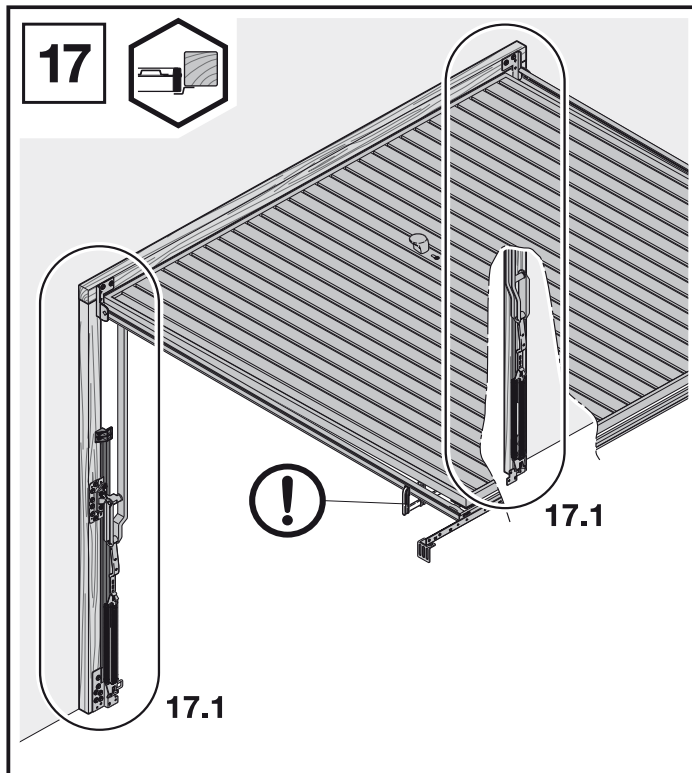

18

